

**Powered Acoustimass[®]-30
Speaker System
AM-30P**



Contents

Safety Information	3
Electrostatic Discharge Sensitive (ESDS) Device Handling	4
Specifications	5
Theory of Operation	6-18
Figure 1. Center Channel Frequency Response	10
Figure 2. Surround Channel Frequency Response	11
Figure 3. Bass and Left/Right Channel Frequency Response	11
Figure 4. Dynamic Equalizer Frequency Response	11
Figure 5. Voltage at Collector of Q381 (Bass Amplifier)	16
Figure 6. Treble Control Frequency Response	16
Figure 7. Simplified Block Diagram of Shared 2 Channel Class-G Amplifier	19
Figure 8. PCB Block Diagram	20
Figure 9. Surround Decoder Block Diagram	21
Disassembly/Assembly Procedures	22-28
Figure 10. Screw Location	22
Figure 11. Cover Latch Rotated In	22
Figure 12. Cover Latch Rotated Out	22
Figure 13. Base-Plate Tabs	22
Figure 14. Module Enclosure Disassembly	24
Figure 15. Cover Assembly	24
Figure 16. Module Assembly Exploded View	25
Figure 17. Heatsink/Amplifier PCB Subassembly	25
Figure 18. Woofer Harness Hookup	27
Figure 19. AM-30P Satellite Cube Array	28
Test Set-Up Parameters	29
Test Procedures	30-33
Part List Notes	34
PCB Identification	34
Main Part List	35
Figure 20. Bass Module Exploded View	36
Figure 21. Module Assembly Exploded View	36
Electrical Part List	37-42
Satellite Part List	43
Figure 22. Satellite Exploded View	43
Packing Part List	44
Figure 23. Packing	45
Integrated Circuits	46-48

SAFETY INFORMATION

1. Parts that have special safety characteristics are identified by the  symbol on schematics or by special notes on the parts list. Use only replacement parts that have critical characteristics recommended by the manufacturer.
2. Make leakage current or resistance measurements to determine that exposed parts are acceptably insulated from the supply circuit before returning the unit to the customer. Use the following checks to perform these measurements:

A. Leakage Current Hot Check-With the unit completely reassembled, plug the AC line cord directly into a 120V AC outlet. (Do not use an isolation transformer during this test.) Use a leakage current tester or a metering system that complies with American National Standards Institute (ANSI) C101.1 “Leakage Current for Appliances” and Underwriters Laboratories (UL) 1492 (71). With the unit AC switch first in the ON position, then in the OFF position, measure from a known earth ground (metal water pipe, conduit, etc.) to all exposed metal parts of the unit (antennas, handle bracket, metal cabinet, screwheads, metallic overlays, control shafts, etc.), especially any exposed metal parts that offer an electrical return path to the chassis. Any current measured must not exceed 0.5 milliamp. Reverse the unit power cord plug in the outlet and repeat test. **ANY MEASUREMENTS NOT WITHIN THE LIMITS SPECIFIED HEREIN INDICATE A POTENTIAL SHOCK HAZARD THAT MUST BE ELIMINATED BEFORE RETURNING THE UNIT TO THE CUSTOMER.**

B. Insulation Resistance Test Cold Check-(1) Unplug the power supply and connect a jumper wire between the two prongs of the plug. (2) Turn on the power switch of the unit. (3) Measure the resistance with an ohmmeter between the jumpered AC plug and each exposed metallic cabinet part on the unit. When the exposed metallic part has a return path to the chassis, the reading should be between 1 and 5.2 Megohms. When there is no return path to the chassis, the reading must be “infinite”. If it is not within the limits specified, there is the possibility of a shock hazard, and the unit must be repaired and re-checked before it is returned to the customer.

CAUTION: THE ACOUSTIMASS® POWERED SPEAKER SYSTEM CONTAINS NO USER-SERVICEABLE PARTS. TO PREVENT WARRANTY INFRACTIONS, REFER SERVICING TO WARRANTY SERVICE STATIONS OR FACTORY SERVICE.

ELECTROSTATIC DISCHARGE SENSITIVE (ESDS) DEVICE HANDLING

This unit contains ESDS devices. We recommend the following precautions when repairing, replacing or transporting ESDS devices:

- Perform work at an electrically grounded work station.
- Wear wrist straps that connect to the station or heel straps that connect to conductive floor mats.
- Avoid touching the leads or contacts of ESDS devices or PC boards even if properly grounded. Handle boards by the edges only.
- Transport or store ESDS devices in ESD protective bags, bins, or totes. Do not insert unprotected devices into materials such as plastic, polystyrene foam, clear plastic bags, bubble wrap or plastic trays.

SPECIFICATIONS

Dimensions:	Module: Satellite:	23.3"W x 7.5"D x 14.0"H (59 x 19 x 35.5cm) 2.2"W x 3.2"D x 4.4"H (5.6 x 8.1 x 11.2cm)
Weight:	Module: Satellite: Packed System:	33 lb. (15kg.) 1 lb. (0.5kg.) 27 lb. (12.3kg.)
Module: Satellites:	2 2	5-1/4" Woofers, 8Ω (parallel) 2-1/4" Twiddlers™ (each satellite)
Finish:	Module: Satellites:	Black or White, scratch-resistant, satin-finish Black or White, painted polymer finish
Amplifier Power:	Bass Channel: Left/ Center/Right Channels: Surround Channel: All Channels driven:	80W maximum into 4Ω resistive load, ≤0.2% THD, from 40Hz-200Hz 40W maximum into 4Ω resistive load, ≤0.2% THD, from 200Hz-15kHz 20W Maximum into 4Ω resistive load, ≤0.2% THD, from 200Hz-15kHz 50W (Bass), 50W (surround), 25W (Left/Center/Right), ≤0.2% THD
Input Impedance:	System: Module: Satellites:	8.3kΩ 4Ω (8Ω woofers wired in parallel) 8Ω (4Ω Twiddlers wired in series)
Output Noise:	A-weighted for Satellite channels	<300μVrms
Output Hum:	Unweighted for bass channel	<2mVrms
Channel Separation:	(Center and Surround) (Volume set at Maximum)	@210Hz >20dB >20dB
Port Tuning Frequency:	Small Chamber: Large Chamber:	110Hz 37Hz
Input Sensitivity:	@1kHz produces maximum rated power in L/R channel outputs (at full volume)	.310Vrms input
Turn-On Delay: (Auto)	(time to speaker unmute)	1.1 ± .2 seconds
Turn-Off Delay:	(time to speaker mute)	.5 ± .1 seconds
Main Voltage:	120Vrms 60Hz 220/240Vrms, 50Hz 120/240Vrms	US version (configurable on PCB) Euro version (configurable on PCB) International version (with voltage select switch)
Power Consumption:	@ nominal mains voltage	350W (max. power)
Standby Power Consumption:	@ nominal mains voltage	15W

THEORY OF OPERATION

1. Overview

The AM-30P is a five channel, 175 Watt, surround-sound powered Acoustimass® loudspeaker, designed to be used with either the CD-20 or CD-5V Music Center. The AM-30P and CD-20 together form the complete Bose® Lifestyle® 30 home theater audio system. Major features of the AM-30P include:

- Patented Acoustimass speaker technology
- Five independent high efficiency Class-G power amplifier channels
- Patented (VideoStage®) surround-sound decoder
- Microcontroller based remote control operation
- Patented low frequency dynamic equalization
- Miniature Jewel Cube® satellite speakers
- Manually adjustable bass and treble tone controls

The bass module portion of the AM-30P is identical to the AM-25P and similar to the AM-5 II Acoustimass loudspeaker, except that the woofers are 8Ω instead of 4Ω, wired in parallel and driven as a single channel. The acoustic response has been modified for powered speaker application. The Jewel Cube satellite speakers have been specially designed to work exclusively in equalized powered speaker applications .

The following theory of operation relates to the electronic module. The electronic module consists of two printed circuit boards (referred to as the “Main” and “Amplifier” PCB) and a magnetically shielded power transformer. Each PCB will be discussed separately. First, a general operation and block diagram overview will be given (See Figure 8 block diagram), followed by a detailed description of each diagram block that will reference the schematic diagram.

2. GENERAL OPERATION AND BLOCK DIAGRAM OVERVIEW

Connection to the CD-20 occurs through a 30 ft. shielded audio cable that carries the following signals:

- Left and right stereo audio (shielded)
- Turn-on signal (10VDC)
- Serial data signal

Figures 1, 2, and 3 show the total system frequency response, from DIN input to speaker output, for the left, right, center, surround, and bass channels.

2.1 General Audio Chain (Refer to Figure 8 PCB Block Diagram)

Audio is buffered and amplified by the DIFF-AMP stage and then passed through a preliminary equalizer stage COMMON-EQ. Next, the audio is passed through a volume control dependent dynamic equalizer stage (consisting of the blocks labeled 37HZ BPF and DYNAMIC EQ VOL) and then presented to the digitally controlled master volume control stage. This is followed by an analog treble control stage (manually adjustable potentiometer). Next, the surround sound decoder splits the left and right channel audio into five components: left, right, center, surround, and bass. Within the decoder block, center and surround channels pass through separate digital volume controls. The bass channel output is fed to an adjustable level control. Each of these channels pass through separate equalizer stages, and then exit the Main PCB to the power Amplifier PCB where they are amplified and sent to each speaker.

THEORY OF OPERATION

2.2 Surround Decoder

Surround channel information is audio that is recorded 180° out of phase (+90° left and -90° right) on to the left and right channels (in equal amplitude). On movie soundtracks this typically represents special effect sounds that are meant to be heard behind the listener. Center channel information (movie dialogue for instance) is audio that is recorded in equal amplitude on to left and right channels that is in phase (0° phase shift between left and right channels), or monophonic.

The surround decoder indirectly determines the phase relationship between left and right channels by detecting the average amplitude of the L (left), R (right), and L-R (left minus right) audio signals. The relationship between these three quantities is enough to determine whether in-phase or out-of-phase signal components exist.

A block diagram of the decoder is shown in Figure 9. Mathematically, the operation of the decoder is essentially defined by the two equations shown in the center and surround multiplier blocks. The bar over the letters “L”, “R”, and “L-R” symbolize the average (rectified) level of these audio signals. How the decoder works is best understood by analyzing the block diagram under certain “pure” signal input conditions, namely: left only; right only; left equals right (mono) ; and surround (L=-R).

Referring to the center channel equation, it can be seen that for either a left only or right only signal input, the numerator and denominator quantity will be identical and therefore the ratio will be equal to one, and when subtracted from one will equal zero. Hence, for this condition, the center channel signal (L+R) will be multiplied by zero and no audio will be passed on to the center channel output. If a mono signal is applied to the left and right inputs, the numerator will be equal to zero, and when subtracted from one will equal one. Hence, the L+R signal is multiplied by one and allowed to pass.

Referring to the surround channel equation, it can similarly be seen that for a left only or right only signal input, the equation reduces to zero and thus no output occurs. For a mono (L=R) input signal, by definition there is no L-R signal, and therefore no output. For the case of L=-R, the numerator is zero and the denominator is non-zero (2L) so that the equation simplifies to $1-0 = 1$. Hence, the L-R signal is multiplied by one and allowed to pass.

The left and right channel outputs are actually the sum of four separate signals. For either a left only or right only input signal, no surround or center channel information exists (as discussed above) and therefore L+R sums with L-R, resulting in 2L at the left output, and 2R at the right output. For a mono signal input (L=R), the center channel L+R output signal subtracts with the left channel L+R input signal, and no left output occurs. Similar action occurs for the right channel output. For an L=-R input signal, the surround channel L-R output signal adds to the right channel R-L signal and subtracts from the left channel L-R signal, resulting again in no left or right channel output.

To summarize the performance of the decoder:

- Left only input results in left only output
- Right only input results in right only output
- Mono (L=R) input results in center only output
- L=-R (right inverted with left) results in surround only output

THEORY OF OPERATION

2.3 Microcontroller (Refer to Figure 8 PCB Block Diagram)

Upon request (via the remote control or console) the CD-20 sends out serial data commands to the AM-30P microcontroller to select mode of operation (2, 3, 5 channel), adjust volume level (master, center, or surround), and control on/off mute. These customer settings are stored in the EEPROM.

The microcontroller also acts as a compressor to automatically regulate the master volume control IC during amplifier clipping (from CLIP DETECT).

The microcontroller also handles mute and unmute commands to the amplifier during power-up and down of the system and monitors the status of several protection circuits in order to shutdown the power supply in the event of a system malfunction such as DC offset at the speaker outputs or abnormal power supply voltage as received by DC FAULT DETECT.

2.4 Power Supply

AC power is applied to the Main PCB and is controlled by TURN-ON/OFF and then exits to the primary winding of the power transformer. Secondary AC voltage of the transformer is rectified and filtered to DC on the Amplifier PCB and distributed to the power amplifier stages and the Main PCB.

3. DETAILED THEORY OF OPERATION (Refer to schematic sheets 1 and 3)

3.1 Power Supply

The 10 Volt DC turn-on signal from the CD-20 is received at pin 1 of DIN connector J5. It is direct coupled to the base of **Q601**. When the AM-30P receives the “turn-on pulse” from the CD-20, **Q604** and **Q601** conduct and provide a current path through opto-coupler **U604**. **U604** is a opto-coupler triac driver that requires a minimum of 5mA to trigger. The opto-coupler conducts through pin 4 and 6 to trigger the AC Mains triac **Q605**. The triac acts as a switch to energize the primary winding of the power transformer.

The universal transformer (dual voltage) has dual primary windings that are wired in series for 240V operation, and in parallel for 120V operation. U.S. and European transformers have single primary windings. Resistor **R626** and capacitor **C613** form a snubber network to suppress the high voltage transients that can occur across the triac.

Secondary voltages are fully developed within 80 milliseconds of turn-on. Three main power supplies are energized: $\pm 17\text{VDC}$ for the low voltage power amplifier rails; $\pm 34\text{VDC}$ for the high voltage (Class-G) power amplifier rails; and $\pm 12\text{VDC}$ regulated for the low power signal processing circuitry. $+5.6\text{VDC}$ for the microcontroller is derived from the $+12\text{VDC}$ supply through resistor **R620** and zener diode **D600**. When the 12V supply crosses the 10V threshold at power-up (at about 40 milliseconds), diode **D606** in the turn-on circuit conducts, and takes over the task of supplying current to opto-coupler **U604**. At this point, the current draw requirement from the CD-20 drops a factor of 100 to less than 100uA, and **Q601** acts as an emitter follower.

THEORY OF OPERATION

3.2 Audio Chain (Refer to the schematic sheets 1 through 3 enclosed)

The following discussion references the left channel electronics. Right channel operation is identical and therefore not specified.

The differential input amplifier stage (op-amp **U13**, pins 1, 2 and 3) buffers and preamplifies the CD-20 output signal. Gain is limited to 10.6dB to prevent potential overload (from the maximum 2Vrms input signal). Capacitors **C102**, **C103**, **C104** and **C162** are for suppression of Radio Frequency Interference (RFI). **D100** and **D101** are protection diodes for input overload or electrostatic discharge (ESD).

The output of the differential amplifier is applied to the “common eq” stage (schematic sheet 2) comprised of op-amp **U6** (pins 8, 12, 13 and 14). This is an equalizer stage that has frequency response corrections that are common to all the satellite speakers, but does not affect the low frequency band below 200Hz, which must remain “flat” so as not to affect the bass channel later in the chain.

The output of the common eq stage is applied to the dynamic equalizer stage. This stage has two paths; one is through the 37Hz bandpass filter (**U6**, pins 1, 2 and 3), the other is through the digitally controlled dynamic bass volume IC (**U8**). The output of the volume control is buffered by op-amp **U17**, and the two paths are summed together through resistors **R120** and **R121**. At full volume, the audio signal flows predominantly through **U8** and **U17**, and thus the frequency response is flat. At lower volume level, more audio flows through the bandpass filter, causing a gradual increasing peak in the frequency response centered at 37Hz. The volume level of **U8** is dependent upon the level of the master volume control (**U9**) and is explained in the next paragraph. The frequency response contour of the dynamic equalizer stage is shown in Figure 4.

The output of the dynamic equalizer stage is applied to the master volume control IC (**U9**). Like **U8** and **U12**, it internally consists of a 12 element resistor ladder network, with digitally controlled analog CMOS switches that adjust signal attenuation in 1dB increments from 0 to -80 dB. When the strobe line (pin 10) is low, volume up/down commands are received from the microcontroller. When **U9** is set between 0 and -20dB, **U8** is kept at 0dB (full volume). As **U9** is decremented below -20dB, **U8** volume begins to decrement from 0dB in step with **U9** (but offset by 20dB).

The output of the master volume stage is applied to buffer amplifier **U7**, which has a gain of 14dB. This is followed by a ± 10 dB treble control stage (potentiometer **R50**). The frequency response graphs of this stage are shown in Figure 6.

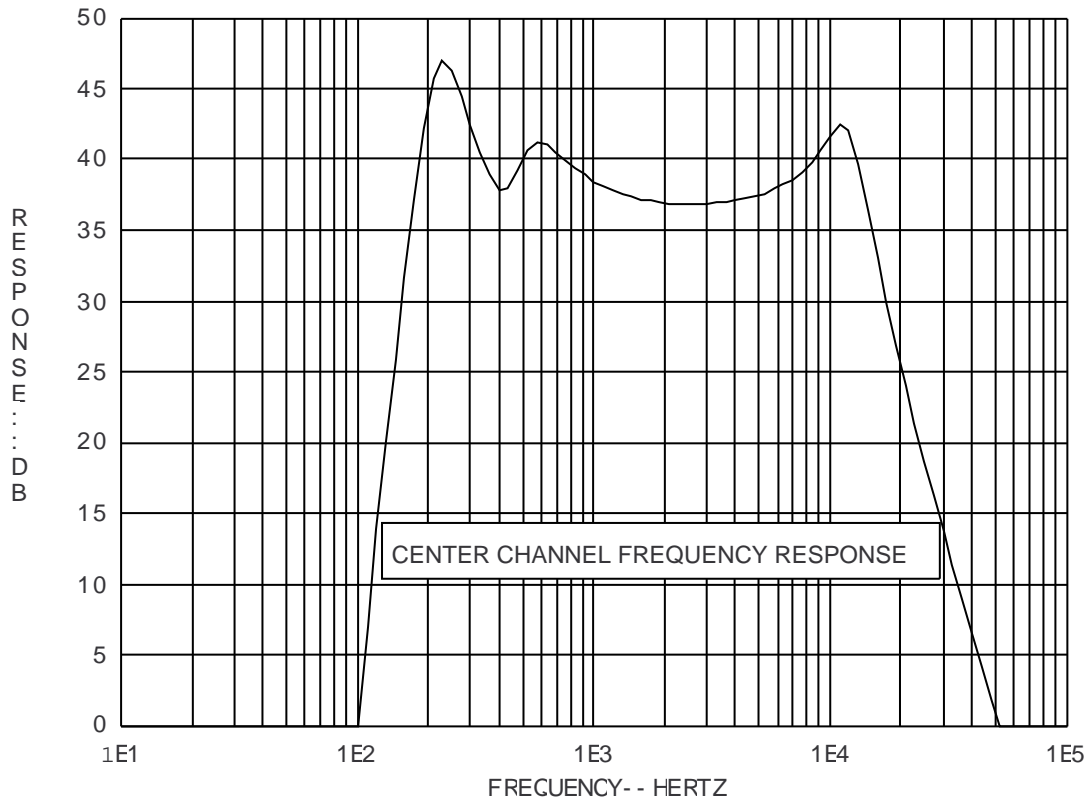

Figure 1. Center Channel Frequency Response

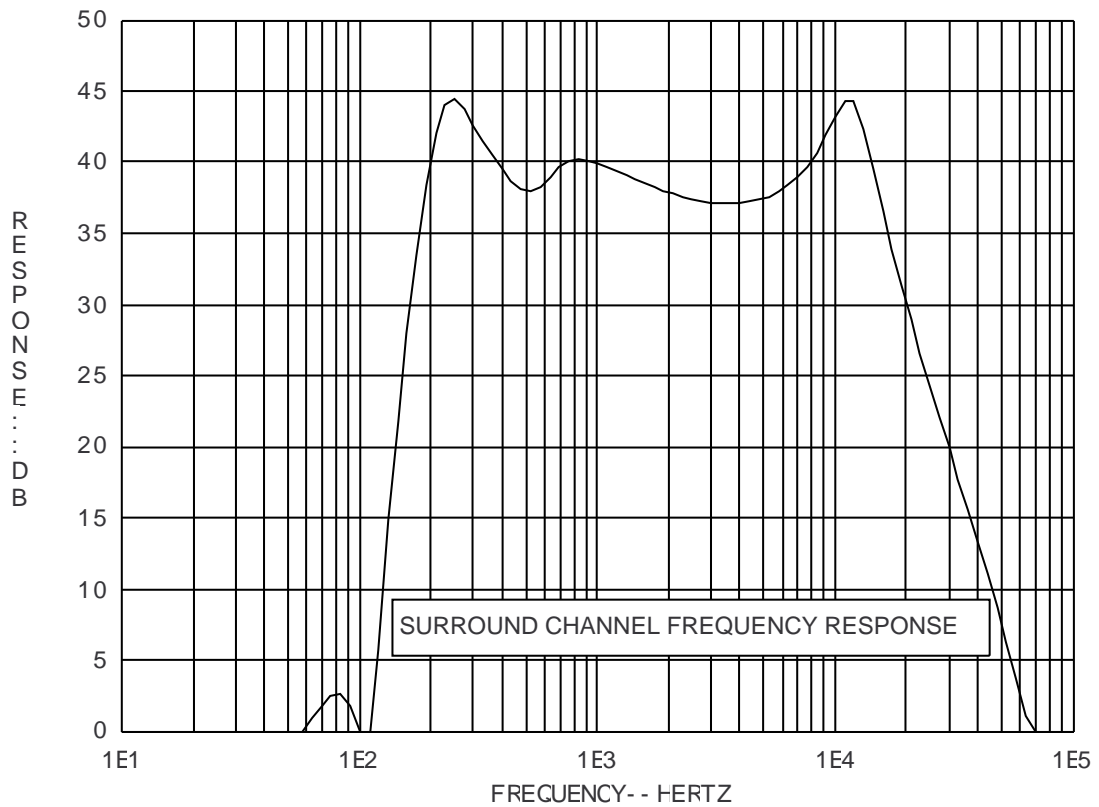

Figure 2. Surround Channel Frequency Response

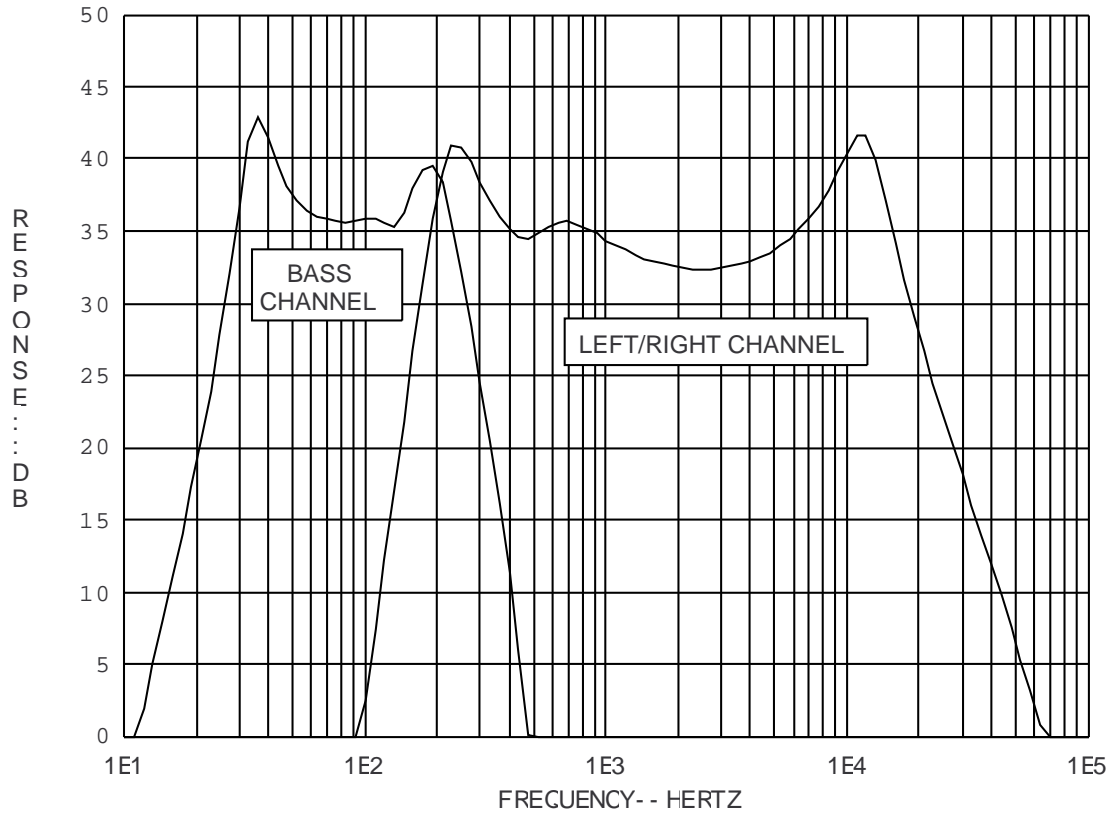

Figure 3. Bass and Left/Right Channel Frequency Response

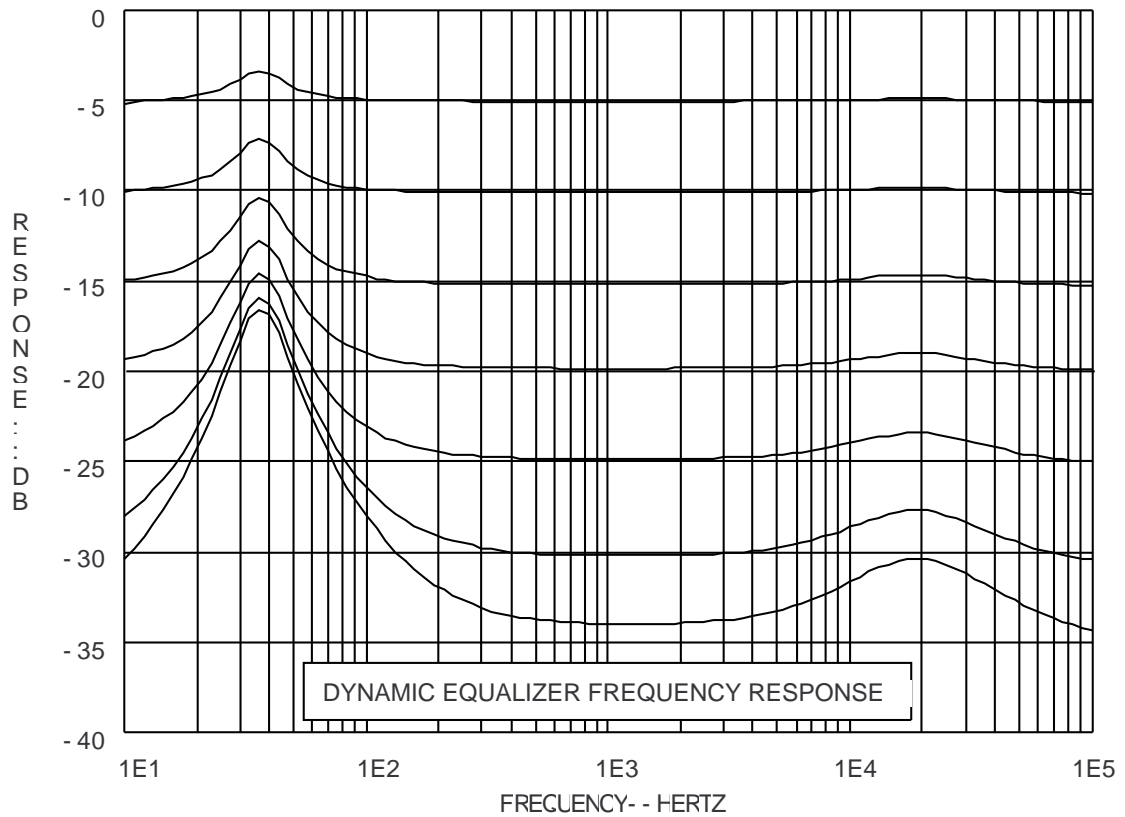

Figure 4. Dynamic Equalizer Frequency Response

THEORY OF OPERATION

3.3 Surround Detector (Refer to schematic sheet 1)

Output from differential amplifier **U13** is applied to a pair of 85Hz 1st order high pass filters, one inverting, the other non-inverting. The inverting stage facilitates full wave detection in the next stage. This output is sent to full wave negative peak detector stage **U700**. **U700** is a quad comparator with open collector output that can only sink current, and thus (with capacitor **C706**) acts as a negative peak detector with fast attack and medium (30ms) decay through 3 k Ω discharge path **R722**. This voltage is further averaged by **C707** at a slower time-constant of 332ms through resistor **R715**. A similar negative peak detector circuit is used for the L-R signal and is comprised of 1/2 of **U701** (pins 11, 12 and 13; 8, 9 and 14).

The voltage outputs of the three level detector stages (**C705**, **C707** and **C709** for L-R, L, and R channels respectively) are converted to current sources through quad op-amp **U702** and quad transistor's **Q700**, **Q701** and **Q703**. Referring to the most basic L-R current source circuit (**U702** pins 8, 9 and 10), the voltage at the inverting input of the op-amp is forced to be equal to the non-inverting voltage by feedback through transistor **Q700**. This voltage appears across resistor **R710**, and forces a current ($V/2000$) to flow through the emitter (and hence collector) of **Q700**. Operation of the two other voltage to current converter stages is similar to the above except that for the (L)-(R) current source the emitter resistors (**R733** and **R735**) are not reference to ground, but instead are referenced across the left and right outputs. Therefore the current developed through either one of the transistors (**Q707** or **Q703**) is proportional to the difference between the left and right voltages at the non-inverting inputs. If left is more positive than right, then the current flows through **Q703**, pins 10 and 8. If right is more positive than left, then the current flows through **Q701**, pins 12, and 14. In either case the current is directed out through **R736** in one direction only. Operation of the (L)+(R) current source is similar except that emitter resistor **R734** is reference to ground, and therefore its current is proportional to the sum of left and right DC voltages. Finally, these three current sources are sent off to the decoder's current controlled gain cells, (see section 3.4 Decoder Gain Cells).

THEORY OF OPERATION

3.4 Decoder Gain Cell (Refer to Schematic sheet 2)

The output of the treble control stage is applied to the input of the surround sound decoder. The decoder is made up of several stages that include **U10**, **U11**, **U12**, and **U14**. At the input of the decoder, left and right audio channels are converted to L+R and L-R signals through summing amplifier **U10**, pins 1, 2 and 3 and differential amplifier **U10**, pins 12, 13 and 14, respectively.

The L+R (center) and L-R (surround) channels are applied to a dual current controlled amplifier **U11** (CA3280 operational transconductance amplifier). This IC is the heart of the decoder, as its momentary gain determines how the signal is steered (added or subtracted) into the various output channels. The gain of this amplifier is directly proportional to the current flowing into pin 3 (labeled I1 on the schematic), and inversely proportional to the current flowing into pin 1 (labeled I4 on the schematic). Unlike a typical op-amp, the output of a transconductance amplifier is a current, not a voltage. However, in effect, it is converted to a voltage when it flows through the fixed parallel load resistor (**R507** or **R407**) for the bottom amplifier.

It is important to understand how this gain block operates for specific audio input conditions. Consider the case of a mono input signal. The $|L|-|R|$ current source (I1) will equal zero and therefore the gain of center amplifier **U11** will be zero (no output at **U11**, pin 13). Thus, the path for the audio signal at **U10**, pin 1 will be only through inverting amplifier **U10** (pins 5, 6 and 7) and the L+R signal will pass forward. Likewise, the gain at surround amplifier **U11**, pin 12 will be zero, but the L-R signal (at **U10**, pin 14) that is allowed to independently pass forward through the inverting input of differential amplifier **U10** is equal to zero, and therefore no output occurs.

Consider the case of an L=-R input signal (pure surround). The $|L|-|R|$ current source will again be zero because the value of this current is the difference between the average amplitude (not phase) level of each of the two channels. So once again the gain of amplifier **U11**, pin 13 is zero. But, in this case, the L+R audio signal at **U10**, pin 1 will be zero, and therefore the net result is that no signal occurs at **U10**, pin 7. The same gain block is used in the surround channel, and likewise, for an L=-R signal, **U11**, pin 12 will be zero, but since there is L-R audio at **U10**, pin 14, it is inverted to the output of **U10**, pin 8.

Consider now the case of a left only or right only input signal. The $||L|-|R||$ and $|L|+|R|$ current sources (I1 and I4) are equal. The gain of the circuit has been designed such that when I1 and I4 currents are equal, the output signal at pin 13 is 1/2 times the output signal at **U10**, pin 1. In other words, the gain of amplifier **U11** is -6.0dB. This signal is then amplified by 6dB at **U10** pins 5, 6 and 7 and exactly cancels with the inverting signal from **U10**, pin 1. Therefore, the overall result is that there is no output at **U10**, pin 7 and no L+R audio is allowed to pass. The same action occurs for the gain cell made up of **U11**, pins 9, 10 and 12 and **U10** pins 8, 9 and 10 in the surround channel.

3.5 Decoder Matrix (Refer to Schematic sheet 2)

The L+R output at **U10**, pin 1 and the output of the Center and Surround gain cells (**U10**, pin 8) are differentially summed into the bass channel path at **U300**, pins 12, 13 and 14. In-phase bass is positively summed, and out of phase bass is inversely summed.

THEORY OF OPERATION

The center and surround channels each pass through an independent digital volume control (internally consisting of a CMOS switched passive resistor ladder network). In five channel mode the range of the center and surround volume controls are deliberately limited, from 0 to -4dB for the center channel, and from 0 to -12dB for the surround channel. In three channel mode, the surround volume control is set off. In two channel mode (conventional stereo) both the center and surround volume controls are set off.

After passing through the volume control stage, the center channel is slightly equalized in the mid-band region by filter stage **U14**, pins 1, 2 and 3. The surround channel is buffered and inverted by op-amp amplifier **U14**, pins 5, 6 and 7. Lastly, the center channel is negatively summed into the left and right channel matrix amplifiers (**U14**, pins 12, 13 and 14 and **U14** pins 8, 9 and 10 respectively). The surround channel is negatively summed into the left channel matrix amplifier, and positively summed into the right channel matrix amplifier.

3.6 Satellite Equalization

After being separated into left, right, center, and surround signals, all satellite channels undergo active filter equalization to band limit the response from 200Hz to 15kHz and correct for satellite speaker frequency response irregularities. Left and right channel equalization (Figure 1) is identical. Center and surround channel equalization (Figure 1 and 2) has been separately developed based on psycho-acoustical evaluation.

3.7 Bass Channel Equalization

The bass channel signals from the decoder are applied to differential amplifier **U300** pins 12, 13 and 14. This stage is also used for gain adjustment and has a range from +6dB (boost) to -14dB (cut). The signal is passed through three stages of equalization to band limit the signal from 37Hz to 200Hz, and provide frequency response correction to the bass module (Figure 3).

3.8 Bass Power Amplifier

The bass power amplifier is a discrete high efficiency Class-G design. Maximum power is 80W into 4Ω at less than 0.1% THD. In Class-G operation the amplifier is powered by two different power supplies depending on the amplitude of the signal input. When the audio amplitude is low, the amplifier runs off of the lower supply rails, but during musical peaks it switches to the higher supply rails. Efficiency is typically increased from 20% to 40%, and power dissipation is reduced by a factor of 2.5. Detailed operation is as follows:

Referring to sheet 3 of the schematic, audio input is applied to the Amplifier PCB at pin 8 of connector J2 and is AC coupled through **C388**. The amplifier is controlled by negative feedback to op-amp U375, which is configured as an inverting amplifier with a voltage gain of 12 (21.6dB). With no signal applied to the input, all output power devices are biased off. For a negative input signal, pin 6 goes high and conducts driver transistor **Q384**. Collector current is pulled through **R390** and **R389** until the voltage drop across **R389** reaches about 1 Volt, at which time the high gain darlington transistor **Q382** begins to conduct emitter current through power diode **D376**, which connects to the +17VDC supply. Collector current from **Q382** flows through the speaker load and the voltage at this node is regulated by feedback to the op-amp via resistor **R398**.

THEORY OF OPERATION

When the audio output voltage approaches the 17VDC power supply rail, output transistor **Q382** begins to saturate and conducts much more base current than the normal maximum of 5mA. At approximately 8mA the voltage drop across 75Ω resistor **R390** exceeds 0.6V and small signal transistor **Q383** begins to conduct. This in turn conducts Class-G Darlington transistor **Q381**, which turns on the 34VDC power supply and reverse biases power diode **D376**, effectively turning off the 17VDC supply. During this period, the wave form at the collector of **Q381** resembles the audio output signal plus the saturation drop of **Q382** (See Figure 5) and **Q381** is operated in the active region (not as a switch), thus sharing the power dissipation.

Crossover distortion and switching transients are not an issue due to the relatively low bandwidth of the amplifier (less than 250Hz) and the ability of the Acoustimass® bass module to roll-off high frequency distortion products. Crossover distortion is less than 0.5% at 200Hz, 1 Watt.

Muting of the amplifier (via remote mute or at system turn-on or turn-off) occurs when the voltage at the mute input line (J2 pin 3) drops below 4.4 volts. Under this condition, **Q377** conducts through **Q378**, and in turn this conducts both positive and negative half cycle mute transistors **Q379** and **Q380**. These transistors saturate and cutoff output transistors **Q382** and **Q387**.

3.9 Satellite Power Amplifiers

Each of the four satellite amplifiers are operated in Class-G configuration, and consist of a 50W, Class AB monolithic integrated circuit (in a multiwatt-15 package, TDA7294). The amplifier is short circuit and thermally protected. External to this IC is a pair of TO-220 Darlington transistors (the same as used in the discrete bass amplifier) to perform the Class-G power supply switching. The following detailed operation is described for the left and surround channel only.

The surround signal is applied to capacitor **C175** and couples to the non-inverting input of the TDA7294 amplifier chip. It is configured as a non-inverting amplifier with a voltage gain of 4 (12dB). The output stage consists of a pair of MOSFET transistors, and the positive FET must develop gate drive well above the supply voltage, and hence there is a bootstrap cap between pin 6 and 14.

With low amplitude signal, the amplifier runs off of the ±17VDC rails through power diodes **D177** and **D180**. The power supply voltage at pin 13 is subtracted by 5.6V zener diode **D176** and divided down by the ratio of $1 + R182/R181$. This bias voltage sets the threshold at which transistor **Q175** turns on. When the audio at the input to the amplifier exceeds the voltage at the emitter of **Q175** by two diode drops, **D175** and **Q175** conduct. In turn this conducts small signal transistor **Q179**, which in turn conducts output transistor **Q176**. A negative feedback loop is established that prevents **Q176** from turning completely on, and the voltage at the collector of **Q176** resembles the audio output wave form plus several volts of saturation headroom. **Q176**, operating in the active region (instead of as an on/off switch), results in shared power dissipation between the transistor and the power amplifier IC. The phase lag created by the input network **R175** and **C177** allows the power circuitry to switch on slightly ahead of the power amplifier at high frequencies (above 8kHz) to minimize turn-on glitch.

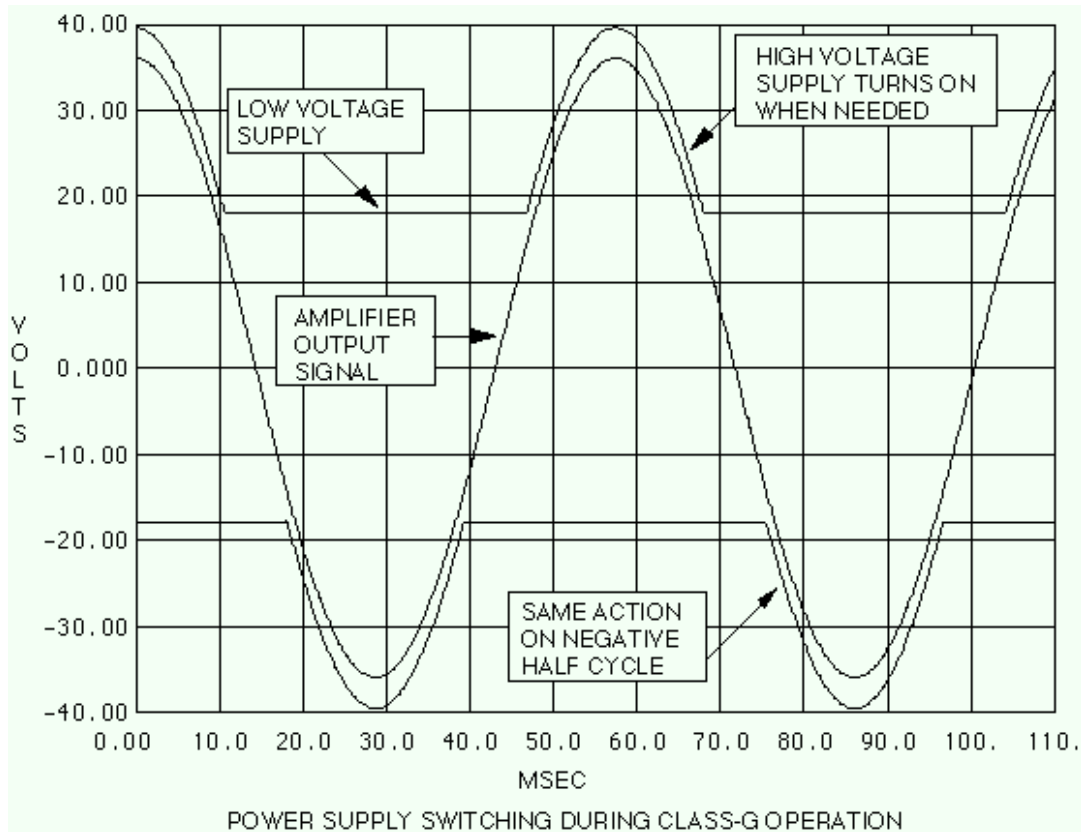

Figure 5. Voltage at Collector of Q381 (Bass Amplifier)

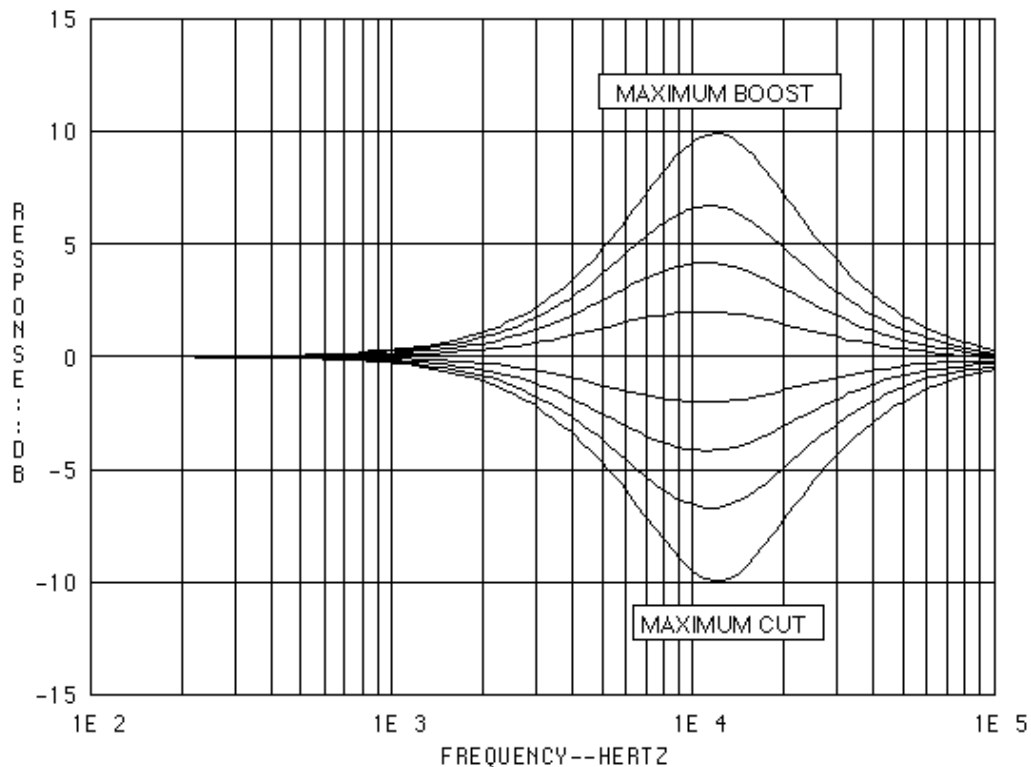

Figure 6. Treble Control Frequency Response

THEORY OF OPERATION

The Class-G switching circuitry previously described for the surround channel amplifier is also controlled by the left channel amplifier. Similarly, when the left audio input exceeds a certain level, diode **D475** conducts and again transistor **Q175** is triggered on. Therefore, the power supply voltage that powers both amplifiers will switch high in response to a request from either amplifier. This is illustrated in Class-G block diagram Figure 7. With a 2:1 ratio in the power supply rails, it can be shown that for typical music, each amplifier has to switch to the high state only 4% of the time. Thus, even two amplifiers in parallel on the same power supply rail does not result in a significant reduction in efficiency, yet a significant cost savings is achieved.

The amplifiers are muted by setting the voltage at pin 10 (mute pin) to less than 1.5VDC. Unmute occurs at 3.5VDC or above. In the AM-30P application, mute voltage is typically zero volts and unmute is 5 volts. The mute and standby lines are tied together through dual diode **D102**. In standby mode the maximum quiescent current to the chip is 3mA maximum, and in the unmute condition is 60mA maximum.

3.10 Compressor Operation (Refer to the schematic sheet 1)

All four satellite amplifier channels are protected by a compressor that momentarily reduces the master volume level of the system if any one of the amplifier channel outputs clip. Detailed operation is as follows:

Each of the satellite power amplifier ICs has a voltage comparator (1/4 of **U3**) connected across its inputs. The outputs of the comparator are wired together to form a logic OR function. Normally, under unclipped audio conditions, the power amplifier IC, through feedback, maintains the voltage across its input terminals to less than 1mV. Each comparator has its non-inverting input biased at +120mV (from voltage divider **R11/R12**) and therefore the output is high. When a particular amplifier clips at the output on the negative peaks by more than 480 mV, **U3** comparator will trip low. This condition is detected by the microcontroller at pin 7, and in response the microcontroller issues a volume down (-1dB) command to master volume control IC **U9**. The microcontroller continues to sample pin 7 approximately once every millisecond, and will issue successive volume down commands until pin 7 goes high (indicating that clipping is no longer occurring). Release time of the compressor, or the rate at which the microcontroller ramps the volume back up after no clipping, is set to approximately 8ms per dB.

3.11 Protection Circuits (Refer to schematic sheet 1)

Several protection circuits tie into the microcontroller, and the status of these lines are continuously monitored. The microcontroller has the ability to power off the system (including itself) in the event of an emergency through the power-off line, pin 13. Normally this pin is high, but when switched low, it conducts through **R641** and **R643** which latches transistors **Q606** and **Q607** on, and current flow through opto-coupler **U604** is interrupted, which in turn opens triac **Q605** and the primary winding of the transformer. Once the power-off command is given the microcontroller locks up and the unit can not be triggered back on until a 10VDC turn-on pulse is reissued from the CD-20. This only happens if the CD-20 is powered off and then back on, which can be done through the remote control. The protection circuits that tie into the microcontroller are described as follows:

THEORY OF OPERATION

The thermal detect line feeds into pin 9 of the microcontroller. This is the output of a comparator that incorporates a thermistor to monitor the temperature of the Amplifier PCB near the heat sink. At room temperature (25°C) the thermistor resistance is 22kΩ. It forms a voltage divider with resistor array **R608** (pins 3-4), and a mirrored voltage divider exists **R608** (pins 1-2) with **R607** on the inverting input of the comparator (**U600** pins 1, 6 and 7). At 80°C (which is the maximum U.L. temperature of the outside cover material), the thermistor drops in value to 1.0kΩ and triggers the comparator low. In response to this, the microcontroller issues a mute command to all the amplifiers. With all amplifiers muted, power dissipation of the system is less than 12 watts (including the transformer) and the temperature should cool enough within a couple minutes to trip the comparator high, at which time the microcontroller unmutes the amplifiers and normal operation resumes.

The offset line feeds into pin 8 of the microcontroller. This is the output of a comparator that monitors the DC offset voltage of all five of the power amplifiers. Each amplifier output is connected to the inverting input of comparator **U600**, pin 8 through a 1MΩ resistor. This node has a normal bias of 2.0VDC. **U600** is configured as a window comparator that will trigger below 1V or above 3V. If any one of the amplifiers experiences a DC offset voltage exceeding 6 volts DC, the comparator will trip low. In response to this, the microcontroller will power-off the system. At power-up there is a one second delay in acknowledging the status of the offset line, due to the time required to charge up capacitor **C605** to its bias voltage.

The power fail line feeds into pin 6 of the microcontroller. This is the output of a comparator that monitors the DC power supply rails. Several power supplies tie into this comparator. The ±12VDC lines connect to the inverting input of **U600**, pin 4 through **R634** and **R635**. The voltage sum at this point is normally 5.6V. The ±17VDC supplies are summed through resistors **R16** and **R17**. Under normal conditions this voltage is zero on the Amplifier PCB. This voltage sum is brought over to the Main PCB through connector J2, pin 13 (protect). There it is summed through resistor **R602** to create a bias of 6VDC at the middle of **D601**. The balancing of this circuit is such that if any one or more of the power supply voltages fail or become heavily loaded and suffer an abnormal voltage drop, the comparator will trip low. In response to this, the microcontroller will power off the system.

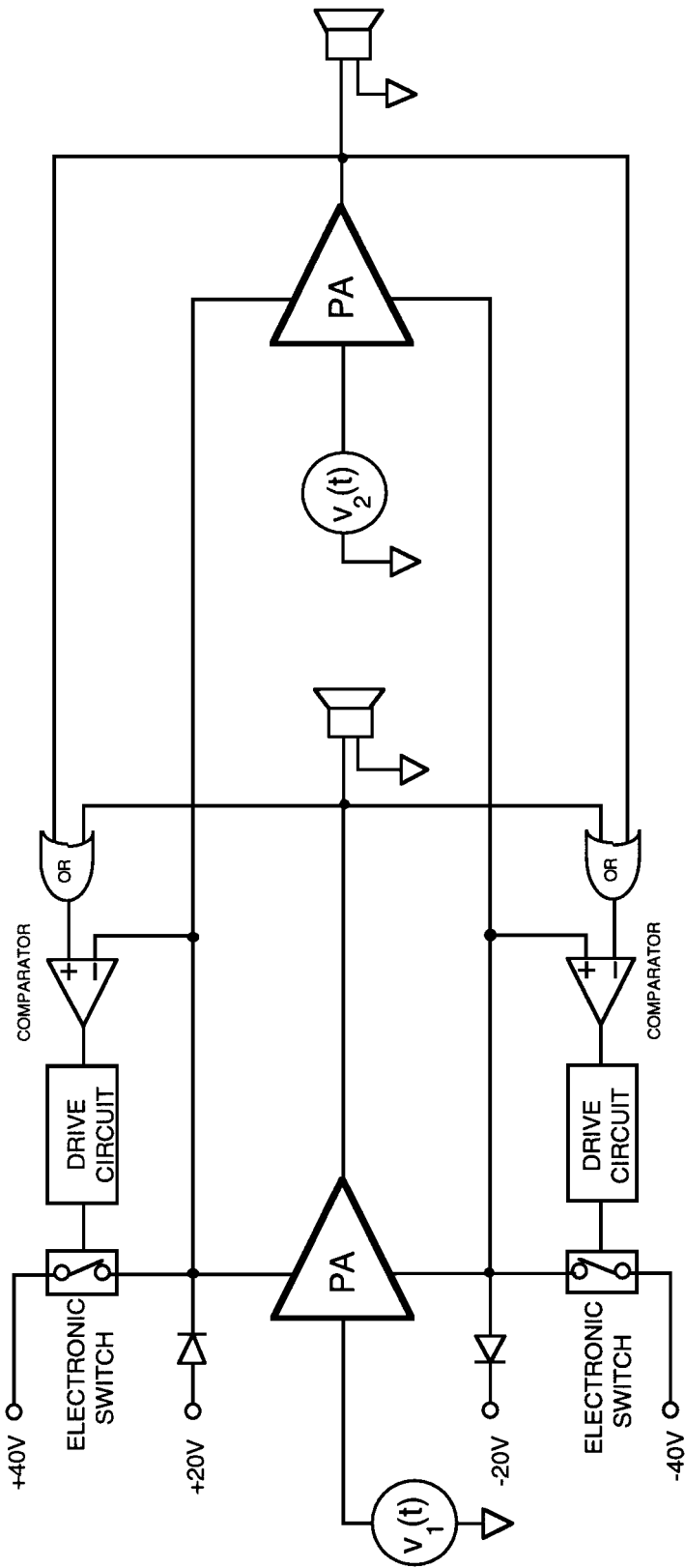

Figure 7. Simplified Block Diagram of Shared 2 Channel Class-G Amplifier

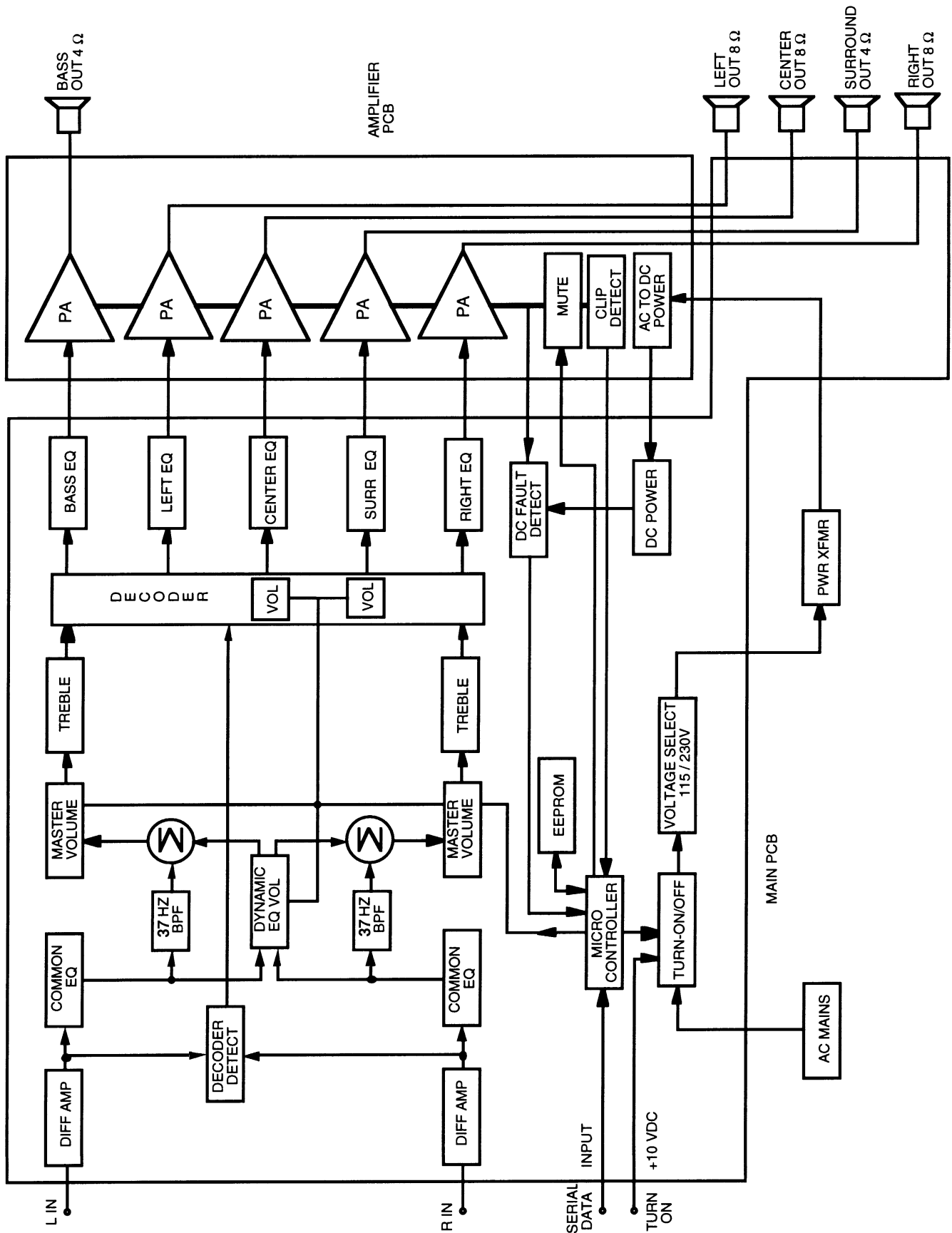

Figure 8. PCB Block Diagram

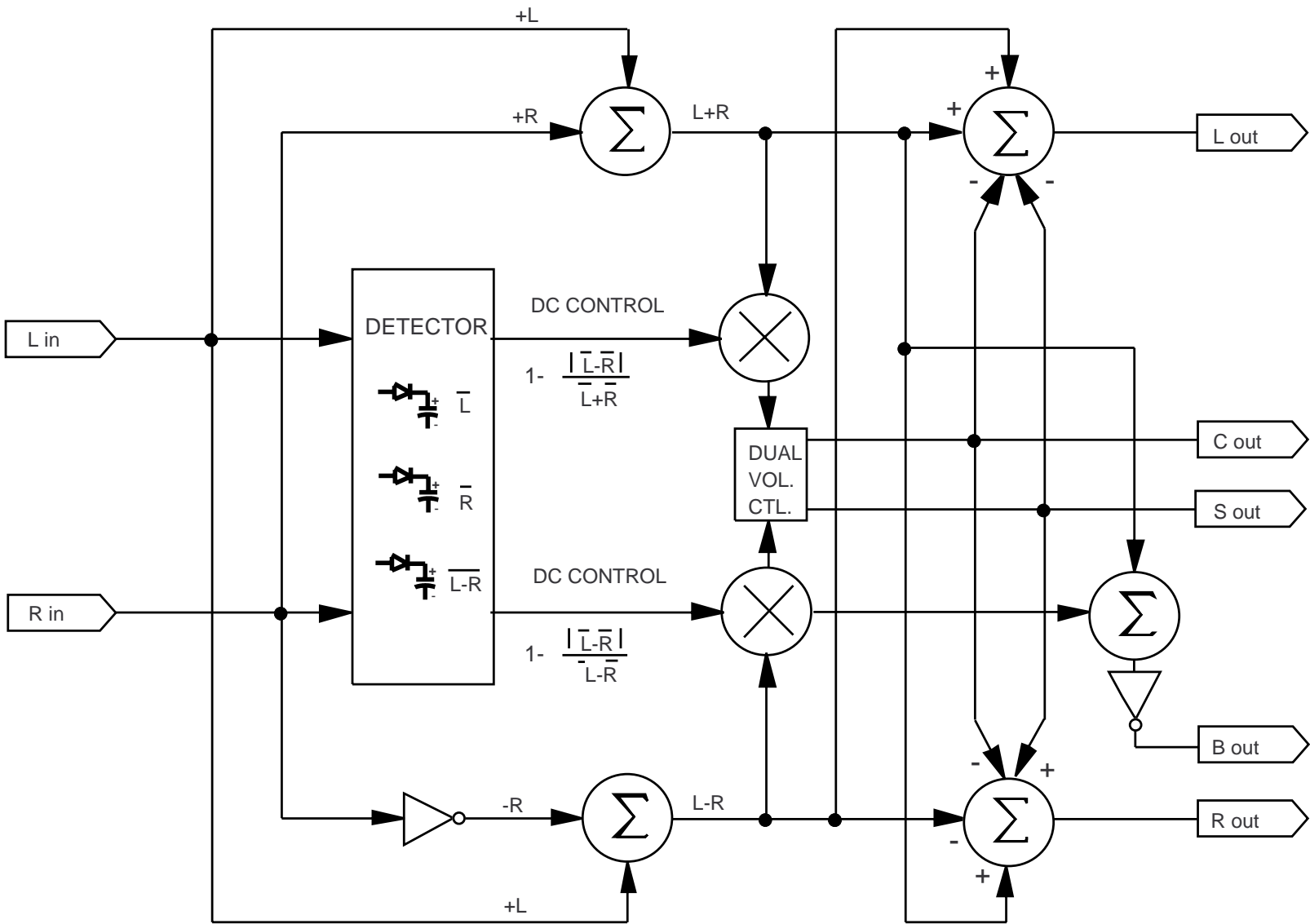

Figure 9. Surround Decoder Block Diagram

DISASSEMBLY/ASSEMBLY PROCEDURES

Bass Module

Note: Numbers in parentheses correspond to the callouts in the Figures referred to in the following procedures.

1. Cover Removal

1.1 Remove the two screws indicated in Figure 10. These two screws were added to secure the top cover on units built on or after September 2, 1996.

1.2 Stand the Base Module up so the open port of the enclosure is facing down. Position the module so you are facing the back of the cover. See Figure 12.

1.3 Remove the two control knobs from the side of the cover.

1.4 Engage one of the cogs of the cover latch with a scribe or small flat-head screwdriver. See Figure 11 and 15.

1.5 Rotate the cover latch counterclockwise until the pointed section of the latch is outside the cover and enclosure. See Figures 11, 13 and 15.

1.6 Put your right-hand thumb into the cover's bass control knob hole. Grasp the front of the enclosure with your right-hand fingers.

1.7 Press the Module's right base-plate tab down with a scribe or small flat-head screwdriver. See Figure 13 and 15 for the tab's location.

1.8 While the tab is pressed down, move the cover forward (away from you) with your thumb. This will disengage the right side of the cover from the right base-plate tab.

1.9 Release the left side of the cover by the same method. Press down the left base-plate tab with a scribe or small flat-head screwdriver. Move the cover forward with your thumb inside the bass control knob hole.

1.10 Once the cover is released from both tabs it can be removed from the enclosure.

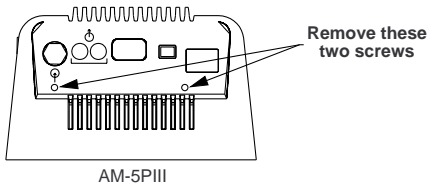

AM-5PIII

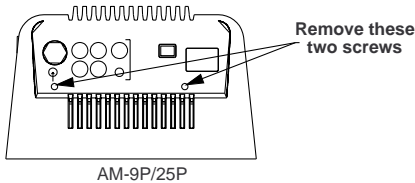

AM-9P/25P

Figure 10. Screw Location

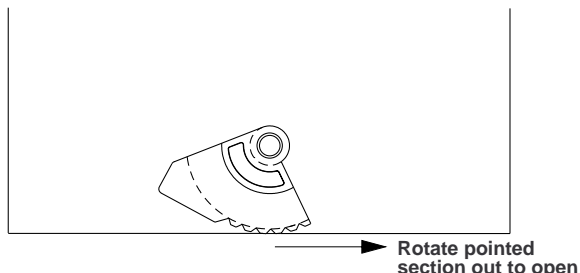

Figure 11. Cover Latch Rotated In



Figure 12. Cover Latch Rotated Out



Figure 13. Base-Plate Tabs

DISASSEMBLY/ASSEMBLY PROCEDURES

Note: Numbers in parentheses correspond to the callouts in the Figures referred to in the following procedures.

2. Cover Replacement

2.1 Place the cover (1) over the module assembly (18). Align the cover so that the Main PCB input and output connectors are inserted into the holes of the cover. Refer to Figure 14.

2.2 Rotate the tab of the cover latch out from the enclosure. Refer to Figure 13 and 15.

2.3 Slide the cover over the base-plate (4) (refer to Figure 16.) until the back of the cover snaps over the base-plate tabs. Refer to Figures 12 and 13.

2.4 Use a flat-head screwdriver or scribe to rotate (to the left) the cover latch tab (3) back into the enclosure.

2.5 Attach the two tone control knobs (2) by pushing them in towards the module. They are keyed and will only fit one way. Refer to Figure 14.

3. Main PCB Assembly Removal

Note: Refer to Figures 14 and 16 for this procedure.

3.1 Perform procedure 1.

3.2 Remove the two screws (7) securing the main PCB (5) to the adapter bracket (6).

3.3 Disconnect the transformer's 5-pin connector from J7, the 8-pin cable from the amplifier, and the flat ribbon cable (8) from connector J8 on the main PCB.

3.4 Release the main PCB (5) from the four snaps of the adapter bracket (6).

4. Main PCB Assembly Replacement

4.1 Place the main PCB (5) onto the adapter bracket (6) component side down. The J5, J9, and J11 input and output connectors should be facing the label side of the module.

4.2 Press the main PCB into the adapter bracket's (6) four snaps.

4.3 Secure the main PCB to the adapter bracket by tightening two screws (7).

4.4 Connect the transformer's 5-pin cable to J7, connect the 8-pin cable from the amplifier's PCB to J10, and the flat ribbon cable (8) to J8 on the main PCB.

4.5 Perform procedure 2.

5. Amplifier PCB Removal

5.1 Perform procedure 3.

5.2 Remove four silver screws (7) and eight black screws (17) securing the adapter bracket (6) to the base plate (4). Lift the bracket away from the enclosure.

5.3 Disconnect the transformer's 5-pin cable from the amplifier PCB's J1 connector. Disconnect the woofer harness connector (9) from the amplifier PCB's J3 connector. Disconnect the flat ribbon cable (8) from the amplifier PCB's J2 connector.

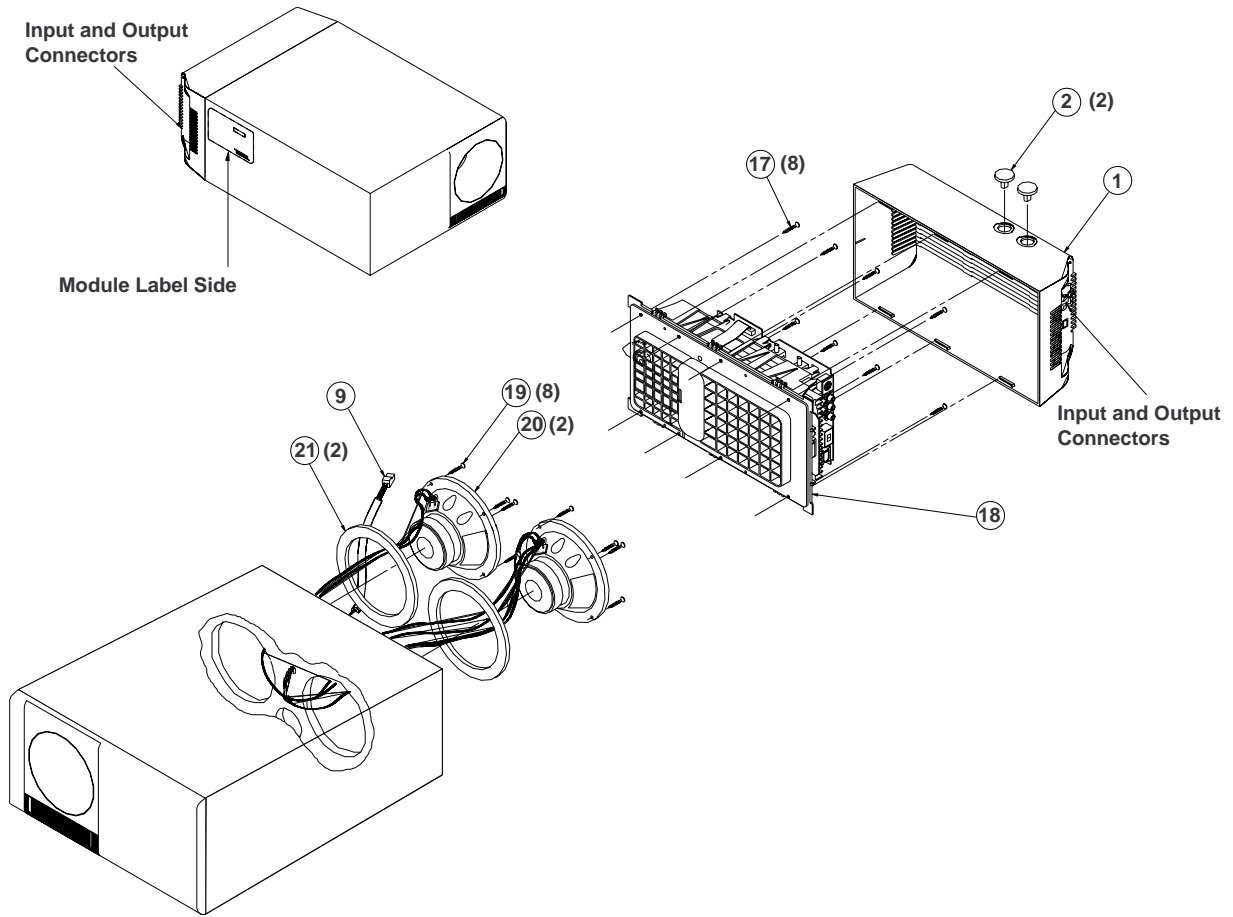

Figure 14. Module Enclosure Disassembly

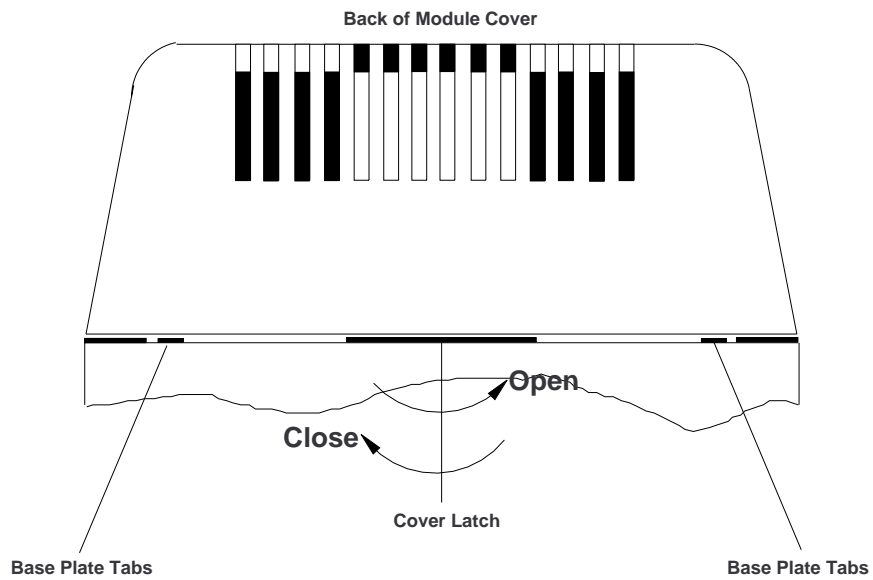

Figure 15. Cover Assembly

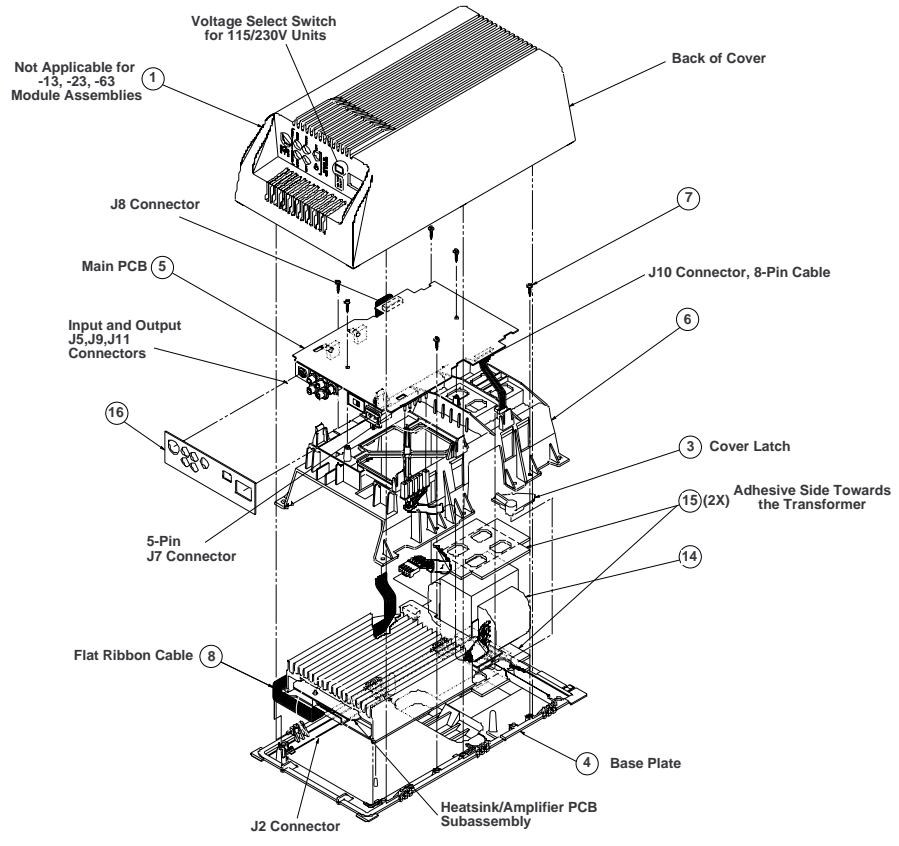

Figure 16. Module Assembly Exploded View

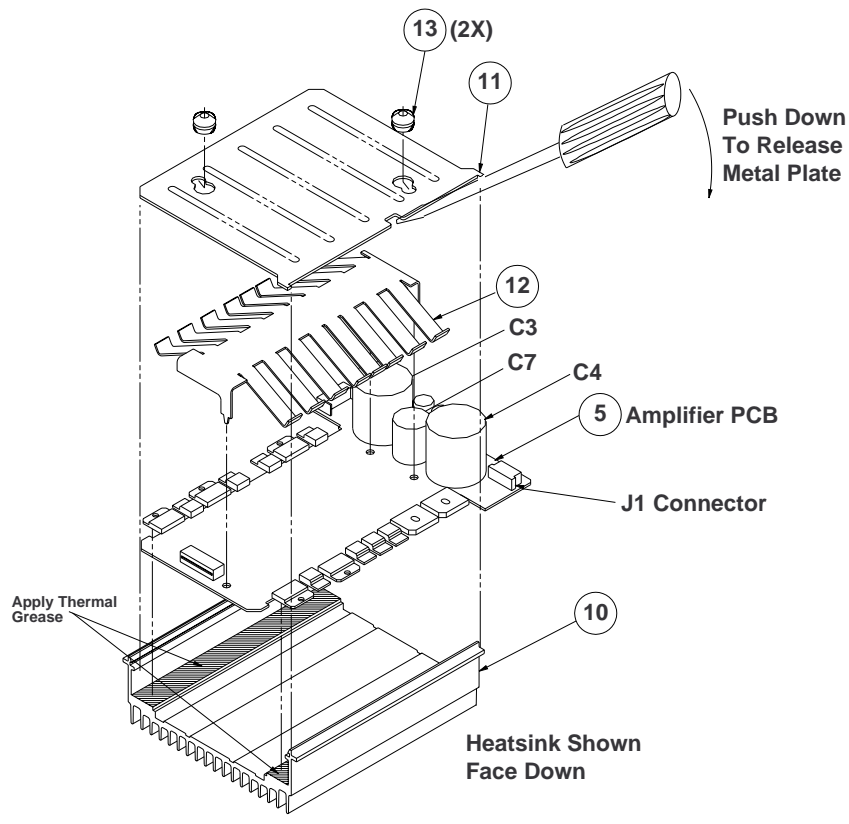

Figure 17. Heatsink/Amplifier PCB Subassembly

DISASSEMBLY/ASSEMBLY PROCEDURES

Note: Numbers in parentheses correspond to the callouts in the Figures referred to in the following procedures. Refer to Figures 14, 16, and 17.

5.4 Lift out the heatsink amplifier PCB subassembly from the base plate (4).

5.5 Place the subassembly on the workbench with the heatsink (10) face down.

5.6 Place the tip of a flat-head screwdriver into the metal plate's (11) small rectangular slot. Quickly pry the heatsink wall back just enough to release the metal plate from the heatsink. Refer to Figure 17.

Note: Do not put a permanent bend in the heatsink wall. A large bend in the heatsink wall will not allow reassembly of the heatsink amplifier PCB subassembly.

5.7 Lift out the spring plate (12) that rests on the power devices.

5.8 Remove the amplifier PCB from the heatsink.

6. Amplifier PCB Replacement

6.1 Place the amplifier PCB (5) into the heatsink (10). The PCB should be component side up with the transistors and ICs resting on the inner sides of the heatsink.

Note: Thermal grease should be applied to the heatsink before seating the PCB.

6.2 Position the spring plate (12) into the holes of the PCB. The spring plate can only be inserted one way.

6.3 Position the metal plate (11) so that the rectangular slot is on the same side as the amplifier PCB's J1 connector. The side marked "Outside" Should be facing out. Insert this side of the metal plate into the slot of the heatsink.

6.4 Press down on the metal plate quickly with both palms of your hand. The plate should snap into the slot of the heatsink.

6.5 Place the heatsink amplifier PCB subassembly, metal plate side down, into the module's base plate (4). The large capacitors fit into the recess of the base plate. Make sure that the rubber grommets engage onto the plastic posts.

6.6 Connect the transformer's 5-pin cable to the amplifier PCB's J1 connector. Connect the woofer harness cable (9) back into the PCB's J3 connector and the flat ribbon cable (8) to the amplifier PCB's J2 connector.

6.7 Place the adapter bracket over the heatsink amplifier PCB subassembly and transformer.

Note: Before securing the adaptor bracket and main PCB over the heatsink amplifier subassembly, route the flat ribbon cable underneath the adaptor bracket and around the heatsink.

6.8 Secure the adapter bracket (6) to the base plate (4).

6.9 Redress any wire harness to the adaptor bracket as needed.

6.10 Perform procedure 2.

7. Transformer Removal

7.1 Perform procedure 5 through 5.2.

7.2 Disconnect the transformer's 5-pin cable from the amplifier PCB's J1 connector.

7.3 Lift the transformer from the module's base plate (4).

DISASSEMBLY/ASSEMBLY PROCEDURES

Note: Numbers in parentheses correspond to the callouts in the Figures referred to in the following procedures. Refer to Figures 14 and 16.

8. Transformer Replacement

8.1 Place the transformer (14) into the recess of the base plate (4). Make sure the transformer is positioned so that the primary wires (red, white, brown, orange, black) that connect to the J7 connector are facing the PCB.

8.2 Connect the transformer's 5-pin cable to the amplifier PCB's J1 connector. Connect the woofer harness cable (9) back into the amplifier PCB's J3 connector.

8.3 Secure the adapter bracket to the base plate and redress any wire harness as needed.

8.4 Perform procedure 2.

9. Woofer Removal

9.1 Perform procedure 1.

9.2 Disconnect the woofer harness cable (9) from the amplifier PCB's J3 connector.

9.3 Remove eight black screws (17) that secure the module assembly (18) to the enclosure. Lift the module assembly away from the enclosure.

9.4 Remove four screws (19) from the woofer (20) under repair.

9.5 Lift the woofer up far enough to expose the wires connected to the woofer's terminals.

9.6 Cut the wires as close to the terminals as possible.

9.7 Remove the woofer from the enclosure.

10. Woofer Replacement

10.1 Strip the ends of the module's wiring harness (9). Connect the yellow wire to the replacement woofer's (20) + positive terminal and the green wire to the - negative terminal. Refer to Figure 18.

10.2 Line up the woofer's gasket (21) over the woofer's baffle panel hole.

10.3 Place the woofer over the gasket. Make sure it is seated evenly over the gasket and baffle hole.

10.4 Secure the woofer to the baffle.

10.5 Secure the module assembly to the enclosure.

10.6 Perform procedure 2.

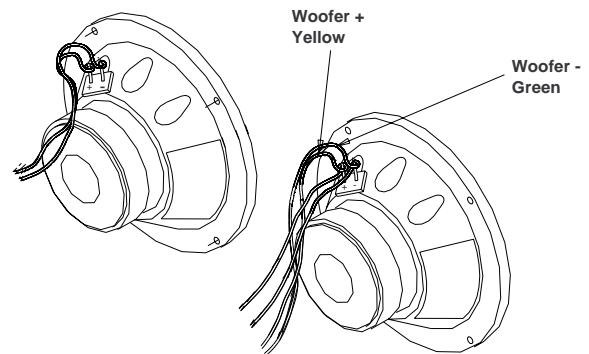

Figure 18. Woofer Harness Hookup

DISASSEMBLY/ASSEMBLY PROCEDURES

Cube Array (Satellite) Procedures

Note: Numbers in parentheses correspond to the callouts in Figure 19.

1. Grille Assembly Removal

1.1 Swivel the cube array so that the grille assemblies (1 and 2) are not aligned. Pull the grille away from the enclosure by prying off one side of the grille with a small scribe.

Note: Do not lose the small grommets (6) that cover the screws located behind the grille.

2. Grille Assembly Replacement

Note: Be sure the grommets (6) are in place before replacing the grille assembly.

2.1 Align the grille assemblies (1 and 2) with the cube array. The curved edges of the grille must be oriented vertically. Snap the grille into place.

Note: The grille assembly with the nameplate (3) should be on the bottom satellite cube.

3. Twiddler™ Removal

3.1 Perform procedure 1.

3.2 Remove the four grommets (6) covering the screws that hold the twiddler (4) in place.

3.3 Remove the four screws (5) holding the twiddler (4) in place. Lift the twiddler out of the enclosure and cut the wires as close to the terminals as possible.

4. Twiddler Replacement

4.1 Strip the wires and connect them to the replacement twiddler's terminals as follows:

4.1.1 If replacing the top twiddler, connect the black wire to the positive (+) terminal and the yellow wire to the negative (-) terminal.

4.1.2 If replacing the bottom twiddler, connect the yellow wire to the positive (+) terminal and the white wire to the negative (-) terminal.

4.2 Place the twiddler into the enclosure and secure it in place.

4.3 perform procedure 2.

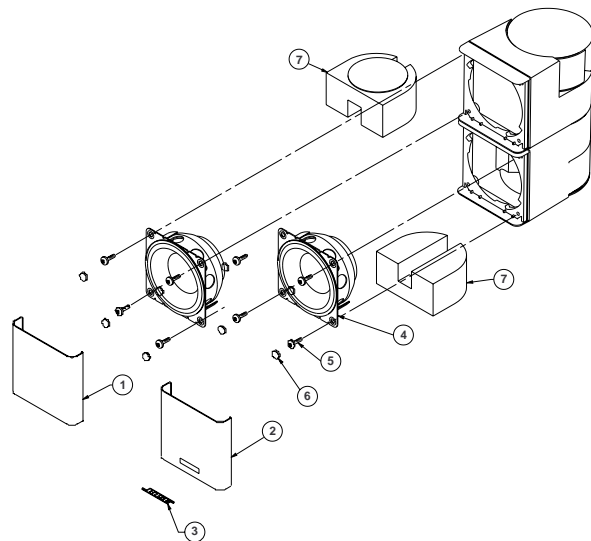

Figure 19. AM-30P Satellite Cube Array

TEST SET-UP PARAMETERS

Before performing the tests described in these procedures, use the following test setup parameters.

SPEAKER OUTPUT LOADING

All tests are to be performed with speaker outputs unloaded except for those specified in the Amplifier Test. Outputs should be loaded as listed below.

Center Out	8Ω, 1%, 50W
Right Out	8Ω, 1%, 50W
Surround Out	4Ω, 1%, 100W
Left Out	8Ω, 1%, 50W
Bass Out	4Ω, 1%, 100W

POTENTIOMETER SETTINGS

Potentiometers **R50** (treble control) and **R306** (bass control) should be set to the center position.

TURN-ON

Apply AC mains voltage. Wait 100ms and apply **+10VDC** between **J5 Pin 1** and **7**, or (if connected) power CD-20 on. Pin 7 is the ground reference point which has to be connected.

MANUAL TEST MODE

The microcontroller can be manually configured to operate in several different "Test Modes" to facilitate input/output troubleshooting and repair without the need for a CD-20 music center (to provide serial data commands to the microcontroller). This is necessary because, by default, all volume control ICs (U8, U9, U12) are at minimum volume and all power amplifier stages are muted in the absence of serial data input. The test modes are induced by grounding Pins 25, 26 and 27 (*labeled TEST 3, TEST 2 and TEST 1 on the top side of the PC board) of U601 as follows:

Note: Ground out the test mode pins before powering up the AM-30P unit.

Test Modes

MODE	TEST 3	TEST 2	TEST1	Condition (L=Left, R=Right, C=Center, S=Surround)
A	Open	Open	Open	Normal (Customer) Mode Operation
B	Open	Open	GND	U8, U9, U12 at full on (0 dB), Power Amps Unmuted
C	Open	GND	Open	U8, U9, U12 at full on (-80 dB), Power Amps Unmuted
D	Open	GND	GND	U9 (L,R) at -40 dB, U12(C,S) at -6 dB, Amps Unmuted
E	GND	Open	Open	U9 (L,R) at 0 dB, U12(C,S) Off, Amps Unmuted
F	GND	Open	GND	U8, U9, U12 at Full On Power Amps Unmuted

NOTE: To access this section of the PC board the top cover must be removed.

TEST PROCEDURES

Note: Use test mode B unless otherwise noted. Use the AM-9P audio cable 176199 to connect test equipment to the AM-30P.

1. Gain Test

1.1 Apply a 1kHz, 100mVrms signal to the left only, right only, center and surround inputs.

Note: Connect both the left and right inputs to get a center output. Connect the left channel out of phase with respect to the right channel to get a surround channel output.

1.2 Reference a dB meter to the applied signal.

1.3 Measure the output according to the following table.

Output	Measurement
Left/Right	+32.4 ± 1.8dB
Center	+36.8 ± 1.8dB
Surround	+37.4 ± 1.8dB

2. Bass Channel Gain Test

2.1 Apply a 100Hz, 100mVrms signal to the left and right channel inputs (in phase).

2.2 Reference a dB meter to the applied signal. The bass channel output should be 35.8 ± 2.0dB.

2.3 Apply a 100Hz, 100mVrms signal to the left and right channel inputs (out of phase by 180°). The bass channel output should be 0 ± 1.8 dB referenced to the measurement taken in 2.2.

DECODER TEST

3. Left Channel

3.1 Apply a 210Hz, 100mVrms signal to the left channel input only.

3.2 Reference a dB meter to the left channel output. Measure the outputs according to the following table.

Output	Measurement
Left Channel	0dB (reference)
Center Channel	≤ -12dBr
Surround Channel	≤ -12dBr
Right Channel	≤ -16dBr

4. Right Channel

4.1 Apply a 210Hz, 100mVrms signal to the right channel input only.

4.2 Reference a dB meter to the right channel output. Measure the outputs according to the following table.

Output	Measurement
Right Channel	0dB (reference)
Center Channel	≤ -12dBr
Surround Channel	≤ -12dBr
Left Channel	≤ -16dBr

5. Center Channel

5.1 Apply a 210Hz, 100mVrms signal to the left and right channel inputs (in phase).

5.2 Reference a dB meter to the center channel output. Measure the outputs according to the following table.

Output	Measurement
Center Channel	0dB (reference)
Left Channel	≤ -20dBr
Right Channel	≤ -20dBr
Surround Channel	≤ -16dBr

6. Surround Channel

6.1 Apply a 210Hz, 100mVrms signal to the left and right channel inputs (out of phase by 180°).

6.2 Reference a dB meter to the surround channel output. Measure the outputs according to the following table.

Output	Measurement
Surround Channel	0dB (reference)
Left Channel	≤ 20dBr
Right Channel	≤ 20dBr
Center Channel	≤ 16dBr

TEST PROCEDURES

FREQUENCY RESPONSE

7. Bass Channel

7.1 Apply a 100Hz, 30mVrms signal to the left and right inputs (in phase).

7.2 Reference a dB meter to the bass channel output. Measure the bass channel output according to the following table.

Frequency	Output	Tolerance
20Hz	-17.0dB	± 3.0dB
35Hz	+6.9dB	± 2.0dB
100Hz	0dB (reference)	-
140Hz	-0.1dB	± 1.5dB
190Hz	+3.8dB	± 1.5dB
400Hz	-24.6dB	± 3.5dB

8. Left, Right Channel Frequency Response

8.1 Apply a 2.5kHz, 100mVrms signal to the left or right channel only.

8.2 Reference a dB meter to the output of the same channel as the applied signal in 8.1.

8.3 Measure the left or right channel output according to the following table.

Note: Perform this test for both channels.

Frequency	Output	Tolerance
150Hz	-8.6dB	± 3.0dB
240Hz	+8.6dB	± 1.8dB
440Hz	+2.2dB	± 1.5dB
750Hz	+3.2dB	± 1.5dB
2.5kHz	0dB (reference)	-
12kHz	+4.8dB	± 1.5dB
20kHz	-11.3dB	± 3.0dB

9. Center Channel Frequency Response

9.1 Apply a 2.5kHz, 50mVrms signal to the left and right inputs (in phase).

9.2 Reference a dB meter to the center channel output.

9.3 Measure the center channel output according to the following table.

Frequency	Output	Tolerance
150Hz	-8.6dB	± 3.0dB
240Hz	+10.1dB	± 1.5dB
440Hz	+1.1dB	± 1.5dB
750Hz	+3.1dB	± 1.5dB
2.5kHz	0dB (reference)	-
12kHz	+4.8dB	± 1.5dB
20kHz	-11.3dB	± 2.5dB

10. Surround Channel Frequency Response

10.1 Apply a 2.5kHz, 50mVrms signal to the left and right inputs (out of phase).

10.2 Reference a dB meter to the surround channel output.

10.3 Measure the surround channel output according to the following table.

Frequency	Output	Tolerance
150Hz	-13.1dB	± 3.0dB
240Hz	+7.0dB	± 1.5dB
550Hz	+0.7dB	± 1.5dB
800Hz	+2.7dB	± 1.5dB
2.5kHz	0dB (reference)	-
12kHz	+6.5dB	± 1.5dB
20kHz	-7.3dB	± 3.0dB

TEST PROCEDURES

11. Dynamic Equalization (volume control dependent).

11.1 Apply a 37Hz, 1.0Vrms signal to the left and right input (in phase). Reference a dB meter to the applied signal. Set the unit to test mode D. The bass channel output should be $-24.2 \pm 1.5\text{dB}$ relative to the input.

11.2 Apply a 9.0kHz, 100mVrms signal to the left and right channel inputs (in phase). Reference a dB meter to the applied signal. Set the unit to test mode D. The center channel output should be $-44.7 \pm 1.5\text{dB}$ relative to the input.

12. Volume IC Mute Test

12.1 Master Volume Mute

Set the unit to test mode D. Apply a 100Hz, 1.6Vrms signal to the left and right channel inputs (in phase). The bass channel output should be $\leq 50\text{mVrms}$.

12.2 Center Channel Mute

Set the unit to test mode F. Apply a 1.0kHz, .5Vrms signal to the left and right channel inputs (in phase). The center channel output should be $\leq 30\text{mVrms}$.

12.3 Surround Channel Mute

Set the unit to test mode F. Apply a 1.0kHz, .5Vrms signal to the left and right channel inputs (out of phase). The surround channel output should be $\leq 30\text{mVrms}$.

AMPLIFIER TEST

13. Small Signal Distortion (.5 W output)

Note: All resistor loads connected, 30kHz LPF. See test set-up parameters.

Channel	Input	Freq.	Dist.
Bass	14mVrms (L+R)	100Hz	<0.4%
Left	64mVrms (L)	9kHz	<0.2%
Right	64mVrms (R)	9kHz	<0.2%
Center	38mVrms (L+R)	9kHz	<0.2%
Surround	30mVrms (L+R 180°out of phase)	9kHz	<0.2%

14. Large Signal Distortion

Note: Resistor loads connected only to the channel under test.

Channel	Input	Freq.	Distortion
Bass	260mVrms	100Hz	<0.2 %
Left	295mVrms	1kHz	<0.2 %
Right	295mVrms	1kHz	<0.2 %
Center	182mVrms	1kHz	<0.2 %
Surround	156mVrms	1kHz	<0.2 %

15. Compressor Test

Note: Load resistors not connected. Momentarily connect test mode B. Set the line voltage to 85Vac.

15.1 Apply a 1.0Vrms, 1kHz signal to the left and right inputs (in phase). The distortion measured at the center channel output should be $< 10\%$ THD.

15.2 Apply a 520mVrms, 100Hz signal to the left and right inputs. The distortion measured at the bass channel output should be $< 5\%$.

16. DC Offset

Note: No signal connected to the inputs.

Channel	Output (DC)
Left	< 15mV
Center	< 40mV
Surround	< 40mV
Right	< 15mV
Bass	< 15mV

17. Noise

Note: All measurements are A-weighted except for the bass channel. The bass channel should be loaded. All inputs shorted.

Channel	Output
Left	< 350uVrms
Center	< 600uVrms
Surround	< 450uVrms
Right	< 350uVrms
Bass	< 2mVrms

TEST PROCEDURES

18. Bass Module Sweep Test

18.1 Apply a 100Hz, 40mVrms signal to the module's audio input terminal. Set the bass control knob (potentiometer R306, Main PCB) to maximum. Sweep the oscillator from 40Hz to 300Hz, listening for any unusual buzz, rub, or extraneous sounds.

Note: There should not be any loud buzzes or rattles from within the module. Redress any wire or component that buzzes or rattles.

19. Air Leak Test

19.1 Connect an oscillator to the module's audio input terminal. Adjust the oscillator to 40Hz, 27mVrms. Listen for air leaks around the cabinet, paying particular attention to the area where the base plate seals to the cabinet. If there is a "whooshing" noise, there is probably an air leak. Repair air leaks as required.

20. Tone Control Test

20.1 Apply a 100Hz, 40mVrms signal to the audio input. Rotate the bass control fully clockwise and counterclockwise from its center position. The frequency response should increase and decrease smoothly without making any scratchy noise. Clean or replace any control that is noisy.

20.2 Apply a 8kHz, 40mVrms signal. Rotate the treble control in the same manner as the bass control. Look for a smooth response. Clean or replace any control that is noisy.

PART LIST NOTES

1. This part is not normally available from Customer Service. Approval from the Field Service Manager is required before ordering.

2. The individual parts located on the PCBs are listed in the Electrical Parts Lists.

3.  This part is critical for safety purposes. Failure to use a substitute replacement with the same safety characteristics as the recommended replacement part might create shock, fire and or other hazards.

4. This part is not interchangeable with the earlier versions of the AM-9P or AM-25P modules.

PCB IDENTIFICATION

To identify which AM-P product you are working on, look on the bottom side of the main PCB for a six digit number with a dash variant. Below is a list of the numbers and the corresponding AM-P module assembly. **Do not mix the PCB's from one AM-P product with another.**

Product	Service Manual	Main PCB Number	Variation
AM-8P	194381	191990-1 191990-2 191990-6	U.S. 120Volt EURO 230Volt DUAL 120/230Volt
AM-25P	177870-S1	190341-1 190341-2 190341-6	U.S. 120Volt EURO 230Volt DUAL 120/230Volt
AM-30P	194382	193133-1 193133-2 193133-6	U.S. 120Volt EURO 230Volt DUAL 120/230Volt

On the bottom of the PCB is a module assembly number. The following is a list of the numbers and the product they correspond to.

AM-8P	189879-131C 189879-231C 189879-631C	U.S. 120Volt EURO 230Volt DUAL 120/230Volt
AM-25P	191170-131C 191170-231C 191170-631C	U.S. 120Volt EURO 230Volt DUAL 120/230Volt
AM-30P	193134-131C 193134-231C 193134-631C	U.S. 120Volt EURO 230Volt DUAL 120/230Volt

MAIN PART LIST

(see Figures 20 and 21)

Item Number	Description	Part Number	Qty	Note
1	COVER, AM9P, REG, WHITE COVER, AM9P, REG, BLACK	172278-11 172278-12	1	
2	KNOB, TONE CONTROL, WHITE KNOB, TONE CONTROL, BLACK	172289-1 172289-2	2	
3	LATCH, COVER	172294	1	
4	BASE PLATE	172288	1	
5	PCB ASSY, AM-30P, 120V PCB ASSY, AM-30P, 230V PCB ASSY, AM-30P, 120/230V	193133-1 193133-2 193133-6	1	changed 5/02
6	BRACKET, ADAPTOR	172287	1	
7	SCREW, HI-LO, 6x3/8, PAN HEAD	147516-06	6	
8	CABLE, FFC, 16 POS.	191124-16	1	
9	HARNESS, WOOFER	172275	1	
10	HEATSINK	172283	1	
11	PLATE, HEATSINK, METAL	172291	1	
12	PLATE, SPRING	172281	1	
13	GROMMET, BASE PLATE	172295	2	
14	TRANSFORMER, 115/230V	182577	1	3 
15	CUSHION, TRANSFORMER	176169	2	
16	GASKET, CONNECTOR, COVER	186845	1	
17	SCREW, TAPP, 8-11x1.25, PAN, XRC/S	172672-20	8	
18	MODULE ASSY, AM-30P, 120V MODULE ASSY, AM-30P, 230V MODULE ASSY, AM-30P, DUAL	193134-131C 193134-231C 193134-631C	1	
19	SCREW, TAPP, 8-11x.75, PAN, XRC/SQ	172672-12	8	
20	WOOFER ASSY, 5.1/4"	172276	2	
21	GASKET, 6.5" WOOFER	104794-08	2	
22	GASKET, TAPE	175548	2	
23	CAP,PORT, BLACK CAP,PORT, WHITE	173310-1 173310-2	1	
24	PORT, BOTTOM, BLACK PORT, BOTTOM, WHITE	173312-1 173312-2	1	
25	PORT SCREEN	145325	1	
26	BUMPER, RECESSED, FOOT, .88"	142839	4	
27	SCREW, HILO, 6-20X.625, PANHD, XRC	172779-10	2	
28	ANCHOR, SCREW, #6, PLASTIC	186207	2	
29	GASKET, TAPE, FOAM, PCB	174676	1	
30	TAPE, FOAM 2"	134936-020	1	
31	FOAM TAPE, 8"	134936-080	1	
-	PORT, FLARE, 1.56"ID	189822-001	1	

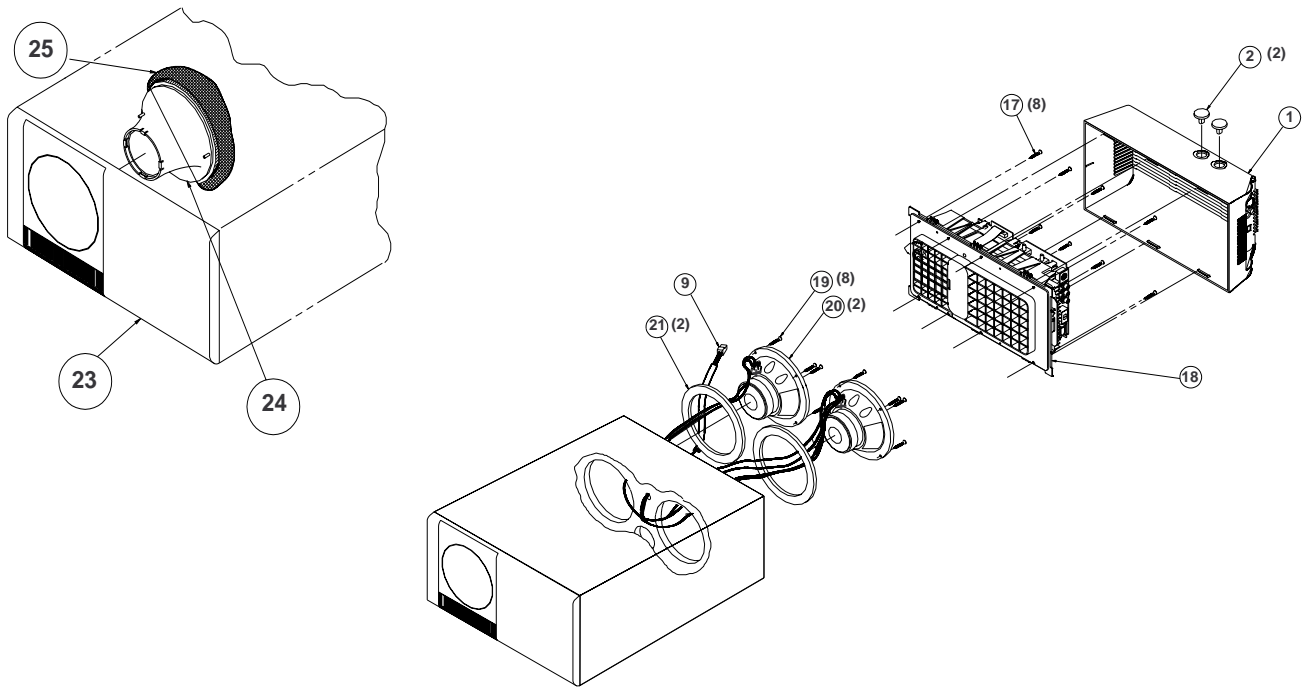
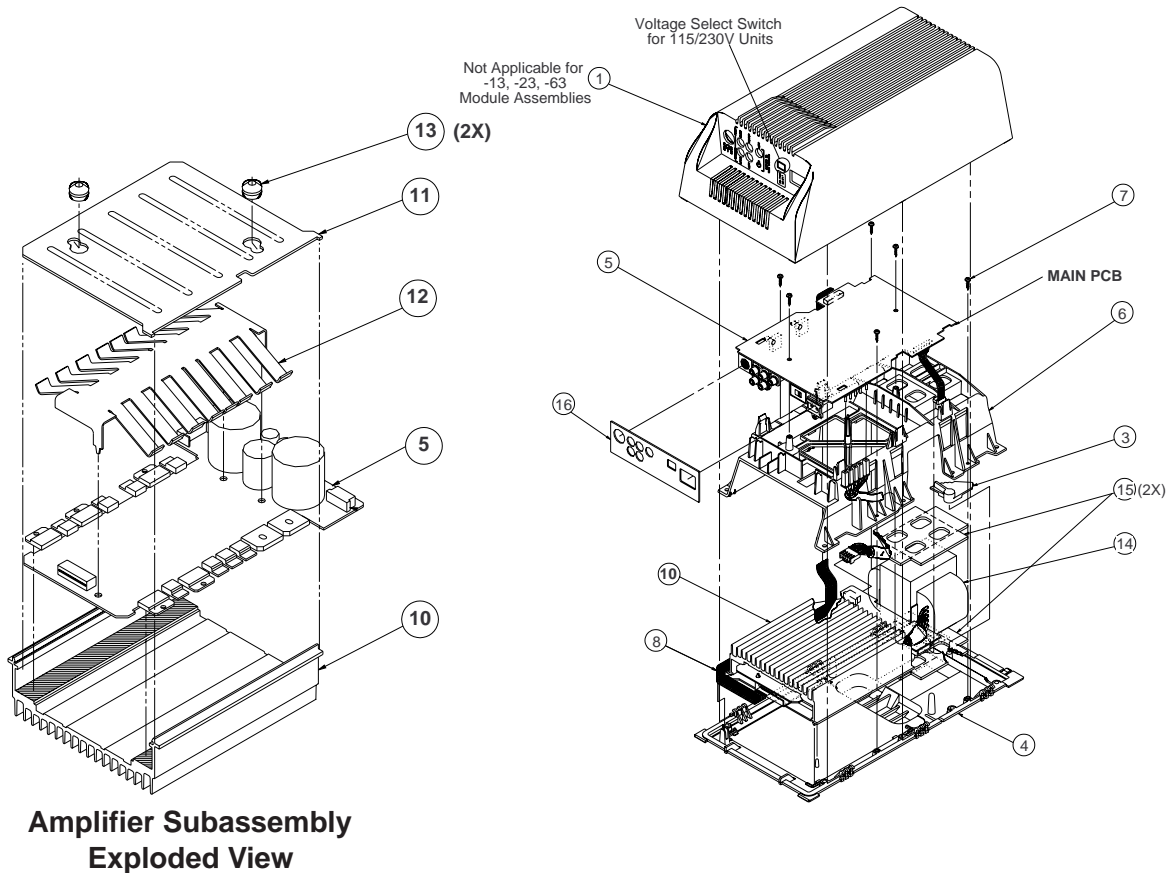

Figure 20. Bass Module Exploded View



Amplifier Subassembly Exploded View

Figure 21. Module Assembly Exploded View

ELECTRICAL PART LIST

Resistors

Reference Designator	Description	Part Number	Note
R3, 4, 129, 190, 192, 229, 290, 292, 384, 610, 619, 622, 631-633, 642, 709, 715, 731	10.0kΩ, CHIP, 0805, 5%	133626-1035	
R7, 13, 15	20kΩ, CHIP, 0805, 5%	133626-2035	
R9, 196, 296, 376, 394, 609, 618, 629	1MΩ, CHIP, 0805, 5%	133626-1055	
R10, 12, 108, 111, 114, 118, 125, 126, 155, 181, 183, 186, 188, 189, 191, 195, 208, 211, 214, 218, 225, 226, 255, 281, 283, 286, 288, 289, 291, 295, 307, 388, 389, 396, 397, 455, 461, 551, 555, 560, 561, 607, 617, 627, 734, 736, 737	1.00kΩ, CHIP, 0805, 1%	133625-1001	
R11, 119, 122, 180, 185, 194, 219, 222, 280, 285, 294, 322, 378, 380, 387, 494, 594, 606, 614, 630	100kΩ, CHIP, 0805, 5%	133626-1045	
R16, 17, 401, 501	8.25kΩ, CHIP, 0805, 1%	133625-8251	
R18, 20, 110, 210	4.42kΩ, CHIP, 0805, 1%	133625-4421	
R19, 21, 620, 623, 733, 735	499Ω, CHIP, 0805, 1%	133625-4990	
R51, 137, 237, 315, 324, 413, 457, 513, 557	10Ω, CHIP, 0805, 5%	133626-1005	
R104, 105, 197, 204, 205, 297, 301, 303, 497, 597	6.81kΩ, CHIP, 0805, 1%	133625-6811	
R106, 123, 134, 135, 206, 223, 231, 235, 611, 616, 710	2.00kΩ, CHIP, 0805, 1%	133625-2001	
R107, 109, 207, 209, 309, 408, 409, 508, 509, 564, 602, 605, 612, 636	4.02kΩ, CHIP, 0805, 1%	133625-4021	
R112, 113, 212, 213	44.2kΩ, CHIP, 0805, 1%	133625-4422	
R115, 116, 215, 216	1.82kΩ, 0805, 1/10W, 1%	133625-1821	
R117, 217	14.0kΩ, CHIP, 0805, 1%	133625-1402	
R120, 150, 184, 193, 220, 250, 284, 293, 460	1.50kΩ, CHIP, 0805, 1%	133625-1501	
R121, 124, 151, 175, 177, 221, 224, 251, 275, 277, 381, 385, 475, 477, 575, 577, 708, 721, 722	3.01kΩ, CHIP, 0805, 1%	133625-3011	
R127, 128, 227, 228, 407, 507, 553, 604	20.0kΩ, CHIP, 0805, 1%	133625-2002	
R138, 238, 311, 320, 321, 377, 625	301Ω, CHIP, 0805, 1%	133625-3010	
R152, 252, 319	127kΩ, 0805, 1/10W, 1%	133625-1272	
R153, 164, 253, 264	19.1kΩ, 0805, 1/10W, 1%	133625-1912	
R154, 254	53.6kΩ, 0805, 1/10W, 1%	133625-5362	
R156, 256, 456, 463, 563, 634	10.0kΩ, CHIP, 0805, 1%	133625-1002	
R157, 160, 257, 260	1.40kΩ, CHIP, 0805, 1%	133625-1401	
R159, 259, 383	200kΩ, 0805, 1/10W, 1%	133625-2003	
R161, 261	1.10kΩ, 0805, 1/10W, 1%	133625-1101	
R162, 262, 462	25.5kΩ, 0805, 1/10W, 1%	133625-2552	
R163, 263	12.7kΩ, 0805, 1/10W, 1%	133625-1272	

ELECTRICAL PART LIST

Resistors (continued)

Reference Designator	Description	Part Number	Note
R165, 265, 453, 511, 514, 515	23.7k Ω , 0805, 1/10W, 1%	133625-2372	
R166, 266	1.47k Ω , 0805, 1/10W, 1%	133625-1471	
R176, 276, 375, 476, 576	16.5k Ω , CHIP, 0805, 1%	133625-1652	
R178, 179, 278, 279, 312, 313, 399, 478, 479, 578, 579, 641, 643	49.9k Ω , CHIP, 0805, 1%	133625-4992	
R182, 187	4.22k Ω , 1206, 1/8W, 1%	124894-4221	
R282, 287	3.65k Ω , 1206, 1/8W, 1%	124894-3651	
R302, 304	1.27k Ω , CHIP, 0805, 1%	133625-1271	
R305	61.9k Ω , CHIP, 0805, 1%	133625-6192	
R310	332k Ω , CHIP, 0805, 1%	133625-3323	
R316	162k Ω , CHIP, 0805, 1%	133625-1623	
R317, 516, 601, 635	27.4k Ω , CHIP, 0805, 1%	133625-2742	
R318	150k Ω , 0805, 1/10W, 1%	133625-1503	
R379	10M Ω , CHIP, 0805, 5%	133626-1065	
R382	200 Ω , CHIP, 0805, 5%	133626-2015	
R390, 395	75 Ω , CHIP, 0805, 5%	133626-7505	
R391	JUMPER, CHIP, 0805	133627	
R392, 648	220 Ω , 0805, 1/10W, 5%	133626-2215	
R393	5.1 Ω , 1206, 1/8W, 5%	124895-5R15	
R398, 600	33.2k Ω , CHIP, 0805, 1%	133625-3322	
R404, 504	15.8k Ω , CHIP, 0805, 1%	133625-1582	
R405, 505	24.3k Ω , CHIP, 0805, 1%	133625-2432	
R410, 411	73.2k Ω , CHIP, 0805, 1%	133625-7322	
R450, 566	2.21k Ω , CHIP, 0805, 1%	133625-2211	
R451	2.74k Ω , 0805, 1/10W, 1%	133625-2741	
R452	68.1k Ω , 0805, 1/10W, 1%	133625-6812	
R454, 554	38.3k Ω , 0805, 1/10W, 1%	133625-3832	
R459, 552	100k Ω , 0805, 1/10W, 1%	133625-1003	
R464, 562	21.0k Ω , 0805, 1/10W, 1%	133625-2102	
R466	2.32k Ω , 0805, 1/10W, 1%	133625-2321	
R510	78.7k Ω , 0805, 1/10W, 1%	133625-7872	
R550	1.33k Ω , 0805, 1/10W, 1%	133625-1331	
R559	93.1k Ω , 0805, 1/10W, 1%	133625-9312	
R603	200k Ω , CHIP, 0805, 5%	133626-2045	
R615	9.1k Ω , CHIP, 0805, 5%	133626-9125	
R626	39 Ω , 1206, 1/8W, 5%	124895-3905	
R628, 640	JUMPER, CHIP, 1206	124896	
R646, 647, 649	1.00k Ω , 0805, 1/10W, 5%	133625-1025	

ELECTRICAL PART LIST

Capacitors

Reference Designator	Description	Part Number	Note
C1, 2, 123, 223, 407, 507	.033uF, 0805, X7R, 50V, 10%	133623-333	
C3, 4	4700uF, EL, BP, 85, 50V, 20%	187394	
C5, 6, 11, 12, 18-20, 28-43, 46-51, 54, 55, 58, 59, 185, 285, 375, 379-381, 485, 585, 601, 610, 710-717	.10uF, 0805, Y5V, 25V, 80%	133624	
C7	4700uF, EL, 85, 25V, 20%	170216	
C8, 14	2200uF, EL, 85, 20%	185929-222E	
C9, 10, 13, 15-17, 109, 117, 184, 209, 217, 284, 401, 403, 476, 484, 501, 503, 576, 584, 600, 700-709	10uF, EL, 20%	137126-100	
C22-25, 161, 177, 178, 180, 182, 261, 277, 278, 280, 282, 309, 383, 386, 461, 477, 478, 561, 577, 578	1000pF, 0805, X7R, 50V, 10%	133623-102	
C62, 63, 65, 179, 183, 279, 283, 384, 609, 611, 614, 616, 618	.01uF, 0805, X7R, 50V, 10%	133623-103	
C102, 103, 202, 203, 382, 387	3300pF, 0805, X7R, 50V, 10%	133623-332	
C104, 162, 186, 204, 262, 286, 615, 621-625	100pF, 0805, COG, 50V, 5%	133622-101	
C105, 106, 153, 205, 206, 253	.047uF, BOX, 85, 63V, 5%	137127-473	
C107, 207	.027uF, BOX, 85, 100V, 5%	137127-273	
C108, 208	330pF, CER, 10%, 50V	140564-331	
C113, 213	.39uF, BOX, 85, 50V, 5%	137127-394	
C114, 214	.0047uF, BOX, 85, 100V, 5%	137127-472	
C115, 215	.022uF, BOX, 85, 100V, 5%	137127-223	
C116, 216, 459	.0022uF, BOX, 85, 100V, 5%	137127-222	
C120, 220	.0056uF, BOX, 85, 100V, 5%	137127-562	
C121, 221, 559	.0018uF, BOX, 85, 100V, 5%	137127-182	
C150, 151, 250, 251, 450, 451	.068uF, BOX, 85, 50V, 5%	137127-683	
C152, 252, 452	.039uF, BOX, 85, 100V, 5%	137127-393	
C155, 160, 255, 260, 406, 455, 460, 555, 560, 602, 603	27pF, 0805, COG, 50V, 5%	133622-270	
C156, 157, 256, 257, 310, 311	.15uF, BOX, 85, 50V, 5%	137127-154	
C158, 159, 258, 259, 718, 719	.018uF, BOX, 85, 100V, 5%	137127-183	
C175, 275, 388, 475, 575, 604	1.0uF, EL, 20%	137126-1R0	
C181, 281, 481, 581	10uF, EL, 85, 25V, 20%	149947-100	

ELECTRICAL PART LIST

Capacitors (continued)

Reference Designator	Description	Part Number	Note
C300, 385, 405, 505	.1uF, BOX, 85, 50V, 5%	137127-104	
C301, 550-553	.082uF, BOX, 85, 50V, 5%	137127-823	
C302	680pF, MONO, COG, 50V, 5%	140564-681	
C303	.056uF, BOX, 85, 63V, 5%	137127-563	
C304	.0027uF, BOX, 85, 100V, 5%	137127-272	
C305, 306	.22uF, BOX, 85, 50V, 5%	137127-224	
C307, 453	.033uF, BOX, 85, 100V, 5%	137127-333	
C308	.001uF, BOX, 85, 100V, 5%	137127-102	
C376	100uF, EL, 105, 16V, 20%	139734-101	
C377, 378	1uF, 1206, Y5V, 16V, 80%	173383-105	
C389, 626-628	270pF, 0805, X7R, 50V, 10%	133623-271	
C456, 457	.12uF, BOX, 85, 50V, 5%	137127-124	
C506	.0033uF, BOX, 85, 100V, 5%	137127-332	
C508	.012uF, BOX, 85, 100V, 5%	137127-123	
C556, 557	.18uF, BOX, 85, 50V, 5%	137127-183	
C605	4.7uF, EL, 20%	137126-4R7	
C613	.0047uF, DISC, 60, AC	149016	
C617	22uF, EL, 20%	137126-220	

ELECTRICAL PART LIST

Diodes

Reference Designator	Description	Part Number	Note
B1, 2	BRIDGE RECTIFIER	187611-001	3 
D1, 3-6, 102, 202, 278, 375, 578, 601	DUAL, SOT-23, BAV99	147239	
D2	ZENER, 12V, 225mW, 5%, 1N5242	135247-5242	
D100, 101, 178, 201, 478	DUAL, SOT-23, BAV99	147239	
D176, 179, 276, 279, 602	ZENER, 5.6v, 225mW, 5%, 1N5232	135247-5232	
D177, 180, 277, 280, 376, 377	1N5402	170219	
D378	ZENER, SOT23, 5%, 5.1V	135247-5231	
D600	ZENER, 5.6V, 225mW, 5%, 1N5232	135247-5232	
D603, 606, 701, 703, 704, 706	1N4531	136603	
D605	ZENER, 3.3V	135247-5226	

Transistors



Reference Designator	Description	Part Number	Note
Q177, 179, 277, 279, 379, 385, 386	PNP, SMALL	119168	
Q175, 180, 275, 280, 377, 380, 383, 384, 601	NPN, TAPE	117921	
Q176, 276, 381, 382	DARL, P, TIP146T	172285	
Q178, 278, 387, 388	DARL, N, TIP141T	172284	
Q375	JFET, SOT,MMBF4392	134738	
Q376, 607, 700-703	BPLR, P, 55V, 150mA, SOT23	258007 Alt. 134743	
Q378	PNP, 2SB560F	140349	
Q605	TRIAC, TO220	178807	3 
Q604, 606	NPN, SOT, MMBT3904	146819	

Integrated Circuits

Reference Designator	Description	Part Number	Note
U1	VOLT REG, 37V, POS	137927	
U2	VOLT REG, 37V, NEG	137928	
U3, 600, 700	VOLTAGE COMPARATOR, LM339	187618-001	
U6, 7, 10, 14, 15, 16, 300, 703	QUAD OP AMP, TLO74D, SOIC	186112	
U8, 9, 12	VOLUME CNTRL, DIP-16, TC9213P	147622	
U11	OP AMP, POS, 36V, CA3280, DUAL	132591	
U13, 17, 375	OP AMP, DUAL, SO-8, NJM2082M	146820	
U175, 275, 475, 575	POWER AMP, AUDIO, TDA7294	170156	
U601	MICRO, uC, SO-28, ST6225M6,	190333	
U602	EEPROM, 1KB, SERIAL, 59C11	147536	
U604	OPTO-TRIAC, PDIP-6, MOC3023T	190334-001	3 
U701	DUAL COMPARATOR, SO-8, LM393	148584	
U702	OP AMP, QUAD, SO14, TL074BCDT	188953	

ELECTRICAL PART LIST

Miscellaneous

Reference Designator	Description	Part Number	Note
J1	HEADER	134290-05	
J2, 8	CONN, HEADER, RTANG, JST 16 FST	191169-16	
J3	CONN, HEADER, RTANG, JST S2P-VH	190552-02	
J4	CONN, HEADER, RTANG, 2.5mm	145402-08	
J5	CONN, DIN, RTANG, 8 POS	176198	
J6	CONN, HOUSING, AC, 2 POS, FEMALE	146563	
J7	CONN, HEADER, 5 POS.	178742-5	
J9, 11	CONN, PHONO JACK	180567or260382	001
J10	CABLE, FLAT, 8P, 24AWG	190701-001	
Y601, 602 (120V)	JUMPER, 22AWG, INSUL, 7mm	135091-070	
F1	FUSE CLIP, 5mm	178548	
L600	INDUCTOR, LM4532, 1uH	178370-1R0	
F601	FUSE, 5X20mm, SLO-BLO, 3M	263401-3000	3 
R5, 6	20 OHM, FUSING, 1/4W	130102-200	3 
R14	THERMISTOR, 20K, ERTD 3FH L 203	177557	
R50, 306	POT, DUAL, 10K, DETENT.	185173	
R100, 200, 645	1.0KΩ, ARRAY, SMT, 4 POS, 5%	186433-1024	
R130, 230, 400, 500, 704, 711, 727	3.9KΩ, ARRAY, SMT, 4 POS, 5%	186433-3924	
R136	1.0 MΩ, ARRAY, SMT, 4 POS, 5%	186433-1054	
R167, 567	300Ω, ARRAY, SMT, 4 POS, 5%	186433-3014	
R608, 638, 700	100KΩ, ARRAY, SMT, 4 POS, 5%	186433-1044	
R664	100 OHM, FUSING, 1/4W	121243- 1211015	3 
X600	CRY, CER, ONATOR, 8mHz	175627	

SATELLITE PART LIST

Item Number	Description	Part Number	Qty Per Assy	Note
1	Grille Assembly, Upper Black	192935-01	1	
1	Grille Assembly, Upper White	192935-03	1	
2	Grille Assembly, Lower Black	192935-02	1	
2	Grille Assembly, Lower White	192935-04	1	
3	Nameplate, Black	178725-01	1	
3	Nameplate, White	178725-02	1	
4	Twiddler™, 2.25" 273244-002 or 291636-001		2	
5	Screw, Tapp, 4-16x.375, Pan, Xrec	181621-06	8	
6	Grommet, Anti-Buzz	183891	8	
7	Foam, Acoustic, Diecut, W/Screen	178714	2	1
-	Harness Assy, Twiddler	178719	1	2
-	H-Ring, Seal	178710-01	1	2
-	Snap Ring, Cube	313536-001	1	2

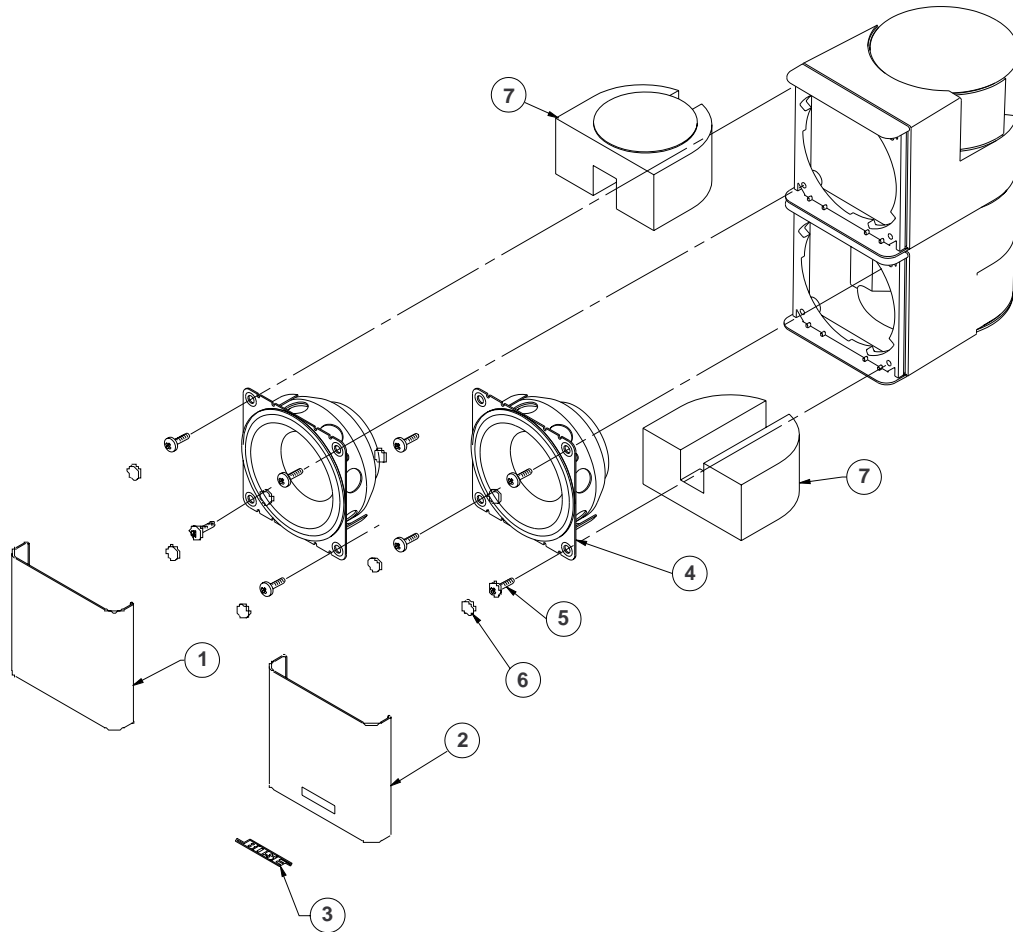



Figure 22. Satellite Exploded View

PACKING PART LIST

Item Number	Description	Part Number	Qty	Note
1	Sat Assy, Black Sat Assy, White	194420-01C 194420-02C	5	
2	Line Cord, 120V, US Line Cord, 230V, UK Line Cord, 230V, EU Line Cord, 240V, AU	146999 134725 148203 134726	1	3 
3	Carton, LS30, US	188005-002	1	
4	Sheet, Quick Start	193149	1	
5	Remote Control	187700	1	
6	Antenna, FM, Dipole, US, 75Ω Antenna, FM, Dipole, Pal Con, Euro	148589 143185	1	
7	Antenna, AM, Loop	178935	1	
8	Power Pack, US, 120VAC Power Pack, AUST., 240VAC Power Pack, UK, 230VAC Power Pack, EU, 230VAC	178371 178373 178374 178375	1	3 
9	Battery, "AA" Size	147538	3	
10	Magazine, 6 Disk	187575	1	
11	Bag, Poly, 4x6x2 mil	143393	1	
12	Packing, D/C, Filler, D/W, LS20	188006	1	
13	Packing, Filler, Accy, CD20	188010	1	
14	Carton, Accy, CD20 Disp	188009-001	1	
15	Carton, D/C, CD20 DISP, LS25	188020-001	1	
16	Packing, Insert, Card, CD20	188022	1	
17	Packing, Top Pad, EPS, Display PK	186424-001	1	
18	Packing, Tray, EPS, LS20 DISP PK	186425-001	1	
19	Envelope, Shipping	180005	1	
20	D/C Carton	172282	1	
21	Cable Pack, R, L, C, White Cable Pack, R, L, C, Black	294522-2010 294522-3010	1	
22	Cable, Speaker, LS/RS, White Cable, Speaker, LS/RS, Black	294523-2010 294523-3010	1	
23	Cable, Audio Input	188694 or 191493		
24	Cable, RCA 6FT	185931-01	1	
25	Screw, Shipping	186273	3	
26	Bag, Poly	103351	1	
27	Warranty Service Center List	187981	1	
28	Bag, Poly	137847	1	
29	Brochure, All Products	188898	1	
30	Foot, 2.03 x .06	183621	4	
31	Packing, Corner Post	148044	2	
32	Packing, Insert, EPS	172279	1	
33	Warranty Card, US Warranty Card, Multi, Language	181357 181460	1	
34	CD, Test, Lifestyle® Home Thtr.	193160	1	
35	CD, Lifestyle Music System	183768	1	
36	Manual, Owner's, LS30	193147	1	

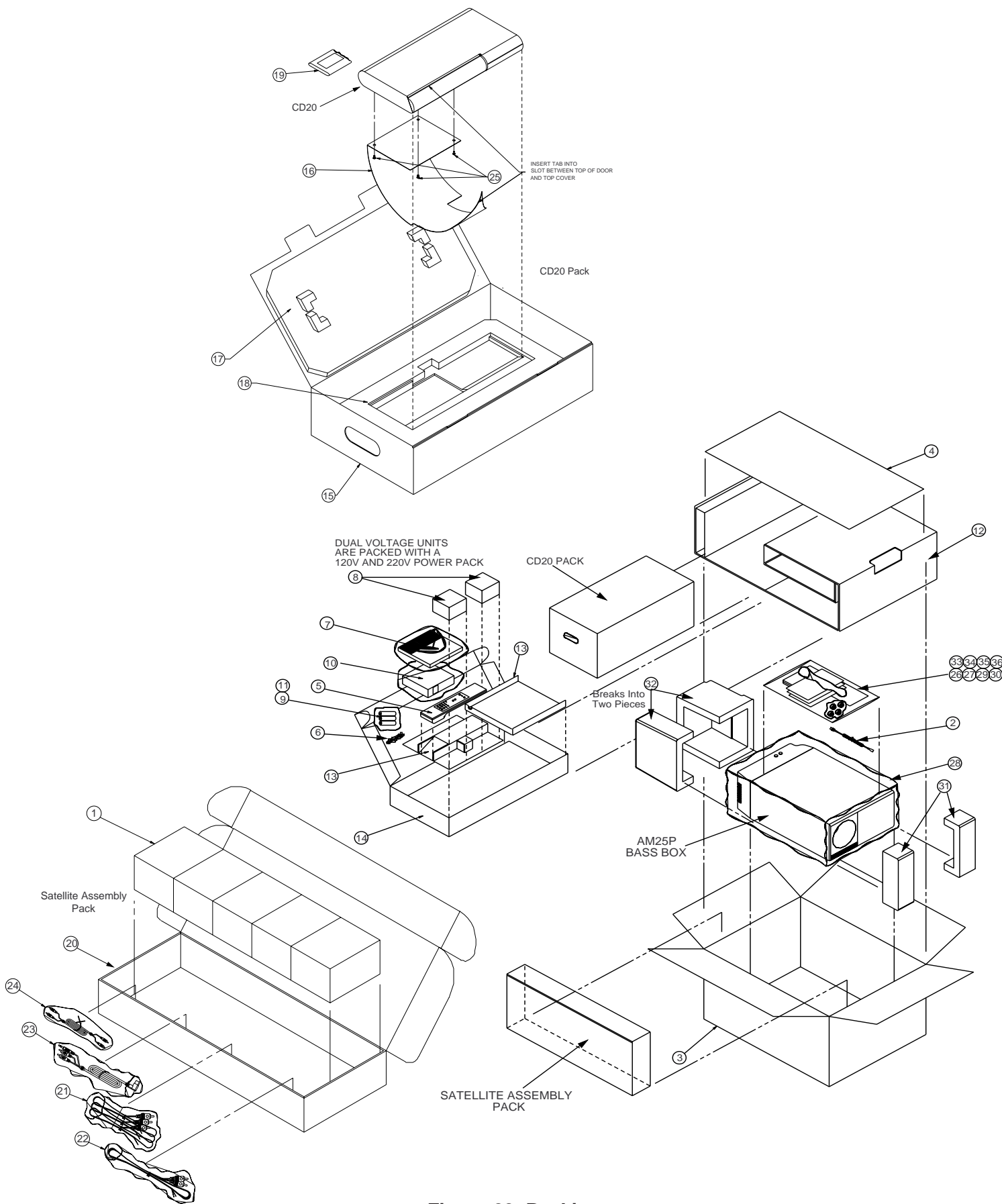
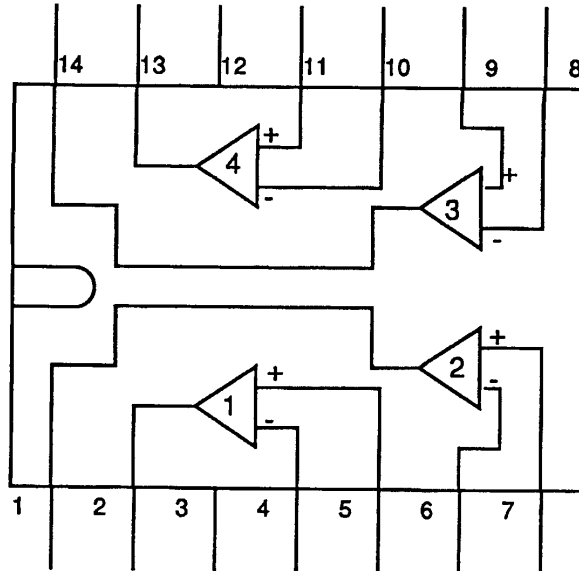

Figure 23. Packing

INTEGRATED CIRCUITS

Pin	Connection
1	Output 2
2	Output 1
3	V+
4	Input 1-
5	Input 1+
6	Input 2-
7	Input 2+
8	Input 3-
9	Input 3+
10	Input 4-
11	Input 4+
12	GND
13	Output 4
14	Output 3



Voltage Comparator
P/N 137929 (LM339N)
Main PCB Assembly
U600, U700, U701

Amplifier PCB Assembly
U3

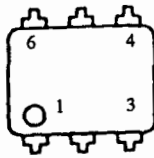
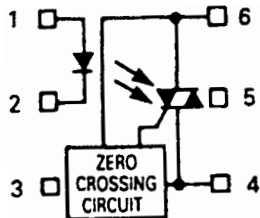
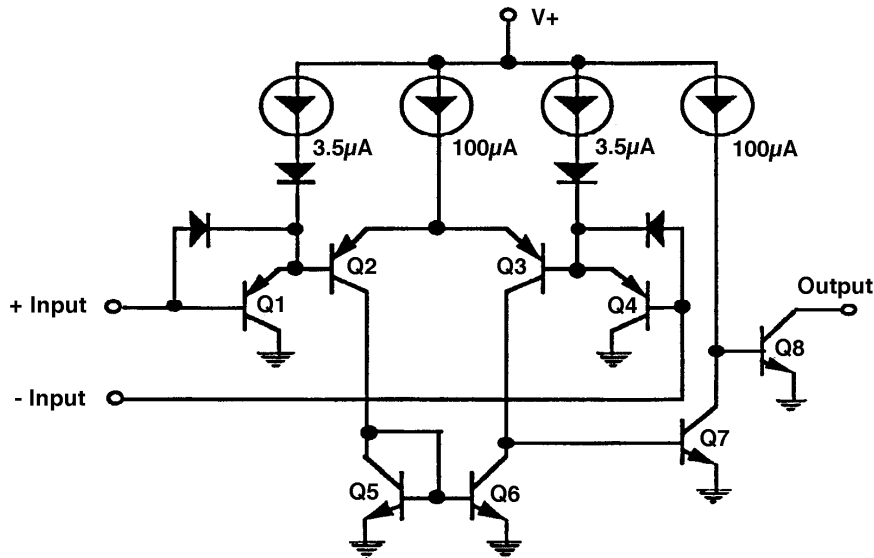

Pin	Function
1	Anode
2	Cathode
3	NC
4	Main Terminal
5	Substrate Do Not Connect
6	Main Terminal

Opto-Triac Driver
P/N 172297 (MOC3063T)
Main PCB Assembly
U604

INTEGRATED CIRCUITS

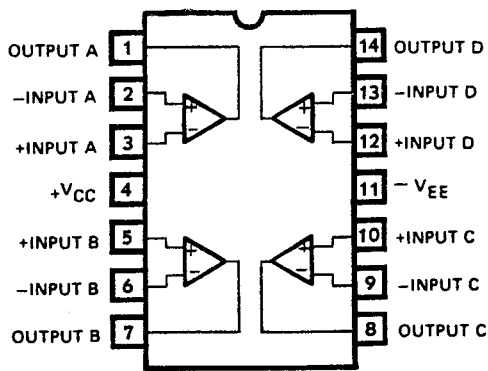

Operational Amplifier, Quad
 P/N 186112 (TL074)
 Main PCB Assembly
 U6, U7, U10, U14-U16,
 U300, U703

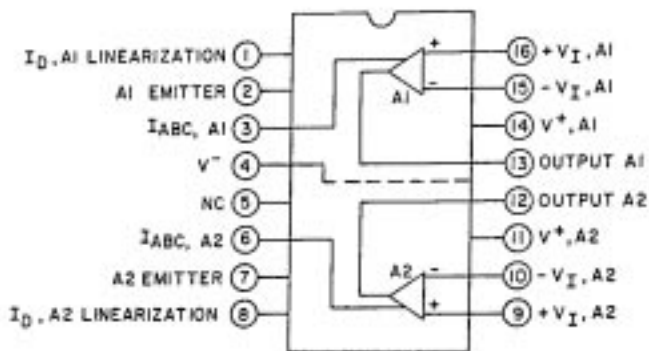
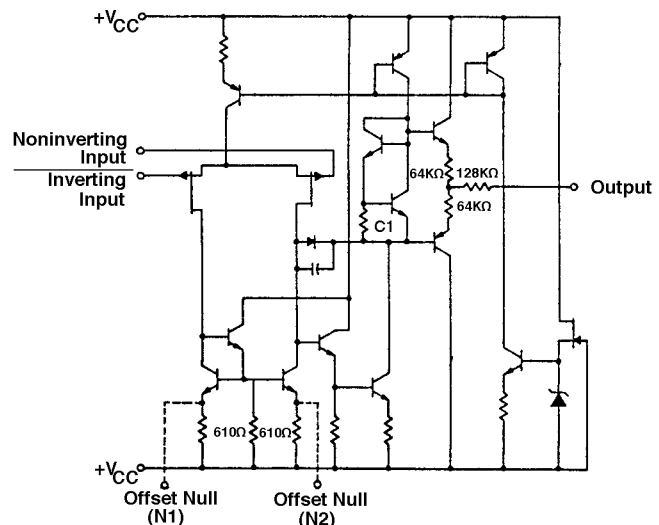

Operational Amplifier, Dual
 P/N 132591 (CA3280)
 Main PCB Assembly
 U11

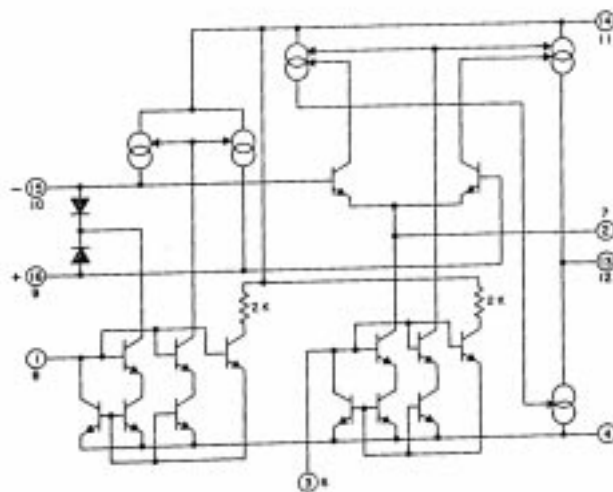

Volume Control
 P/N 147622 (TC9213P)
 Main PCB Assembly
 U8, U9, U12

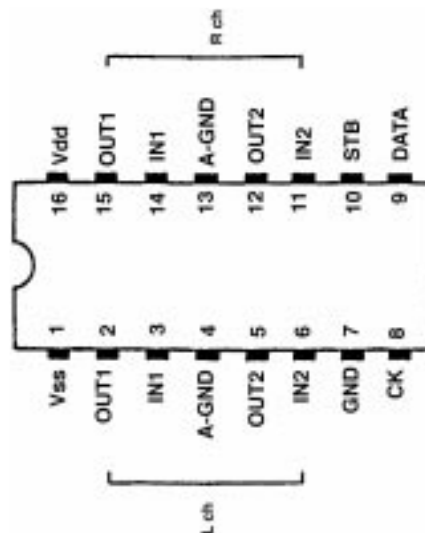

INTEGRATED CIRCUITS

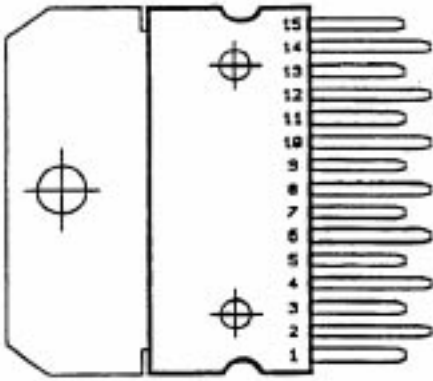

Pin	Function
15	-Vs (Power)
14	Out
13	+Vs (Power)
12	N.C.
11	N.C.
10	Mute
9	Stand-by
8	-Vs (Signal)
7	+Vs (Signal)
6	Bootstrap
5	N.C.
4	SUR
3	Non-Inverting Input
2	Inverting Input
1	Stand-by GND

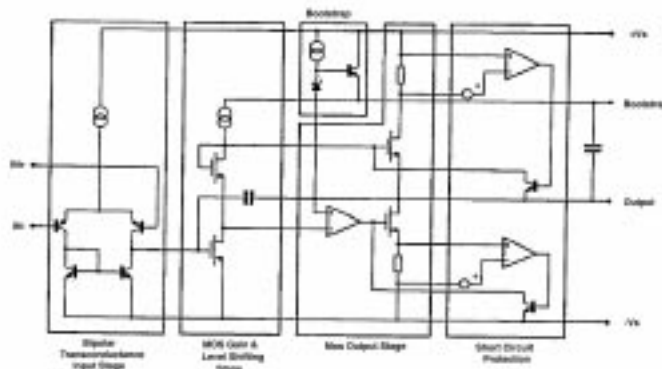

Audio Power Amplifier
 P/N 170156 (TDA7294)
 Amplifier PCB Assembly
 U175, U275, U475, U575

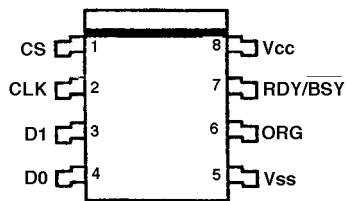

EEPROM, 1KB
 P/N 147536 (59C11)
 Main PCB Assembly
 U602

