

NOTES:  
Power supply voltages drop to zero when console is turned off.

SHEET = 1

SAFETY CONTROLLED

**BOSE**  
FRAMINGHAM, MA 01701-9168

AM-25/30P Series II  
DSP PCB Assembly  
Part Number 251571

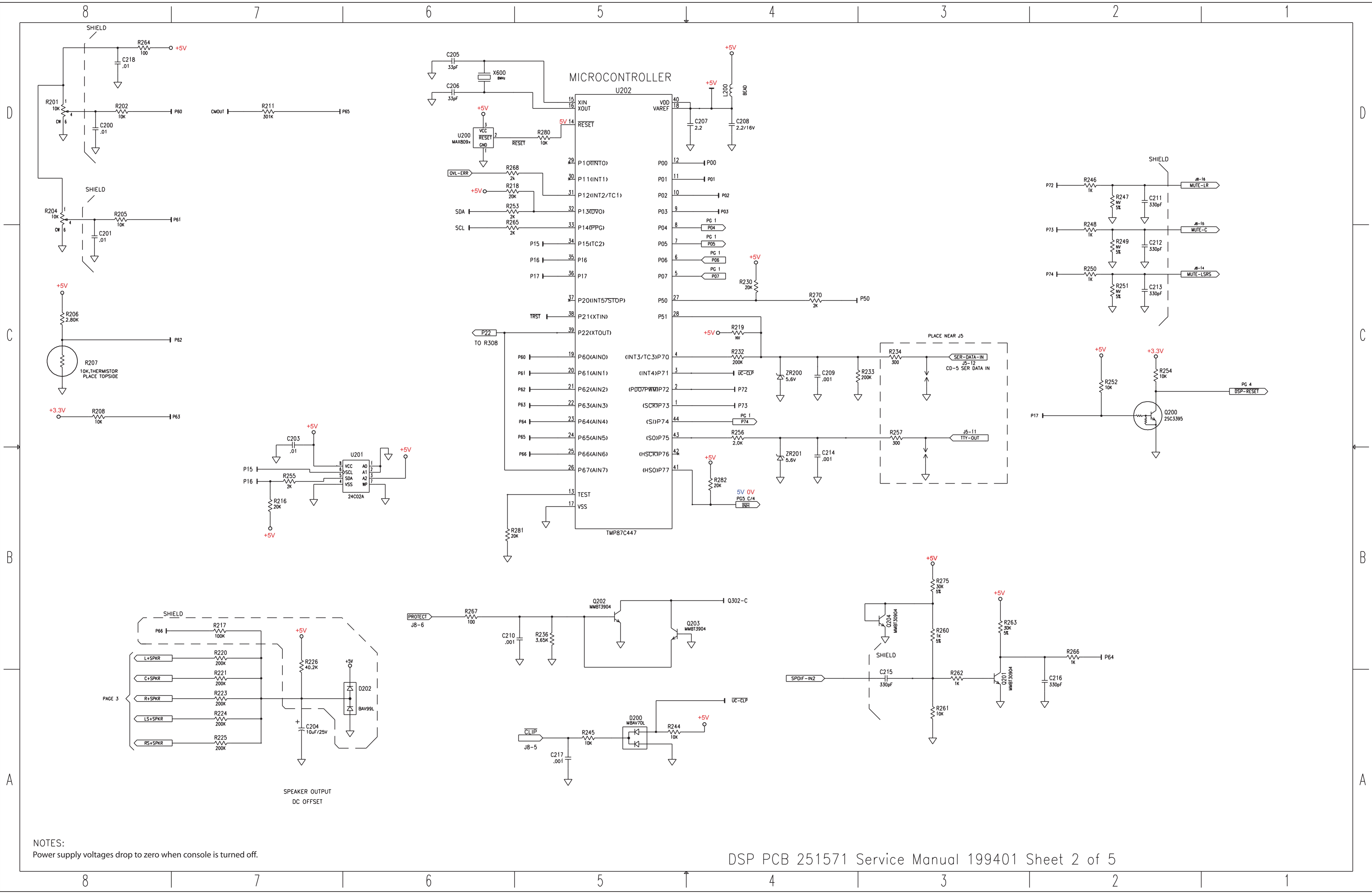

NOTES:  
Power supply voltages drop to zero when console is turned off.

8 7 6 5 4 3 2 1

D

C

B

A

D

C

B

A

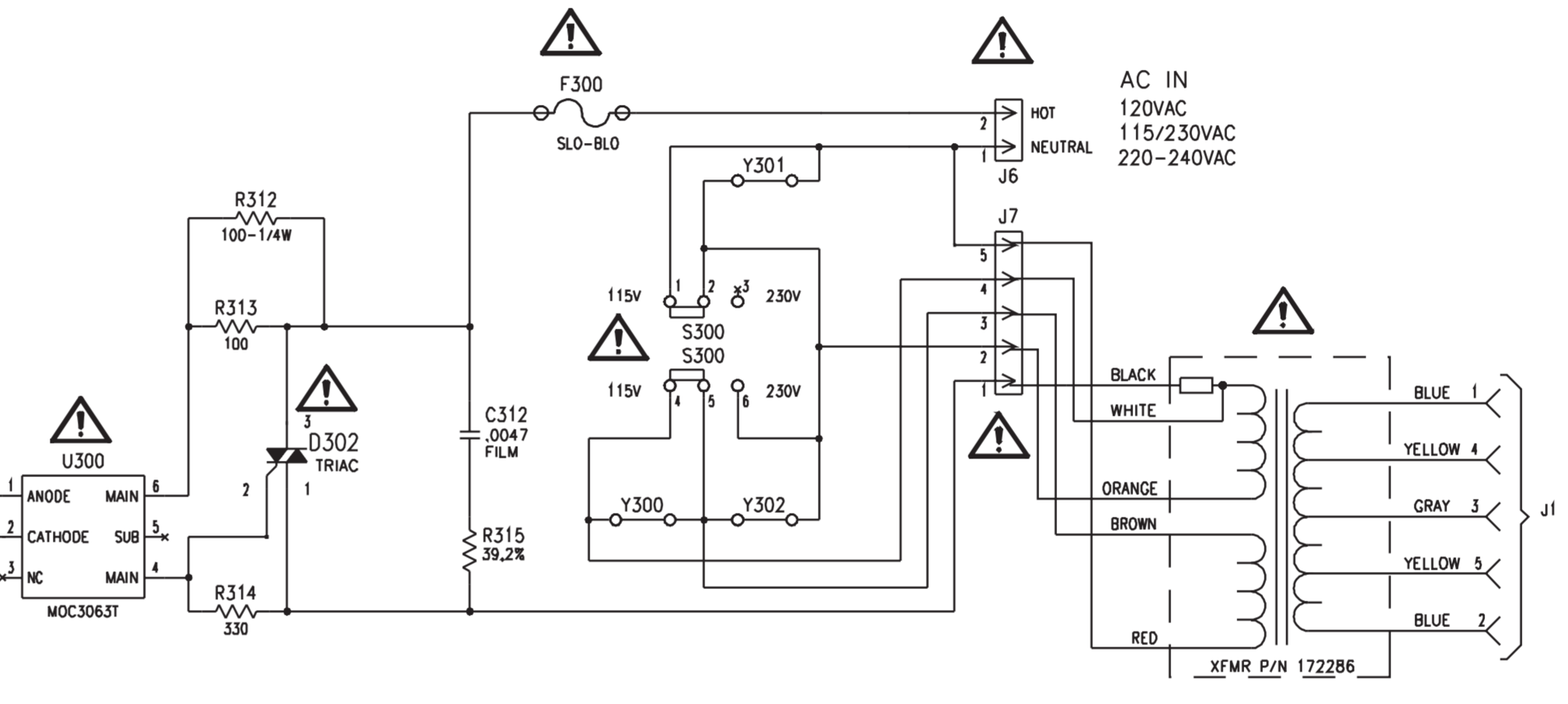
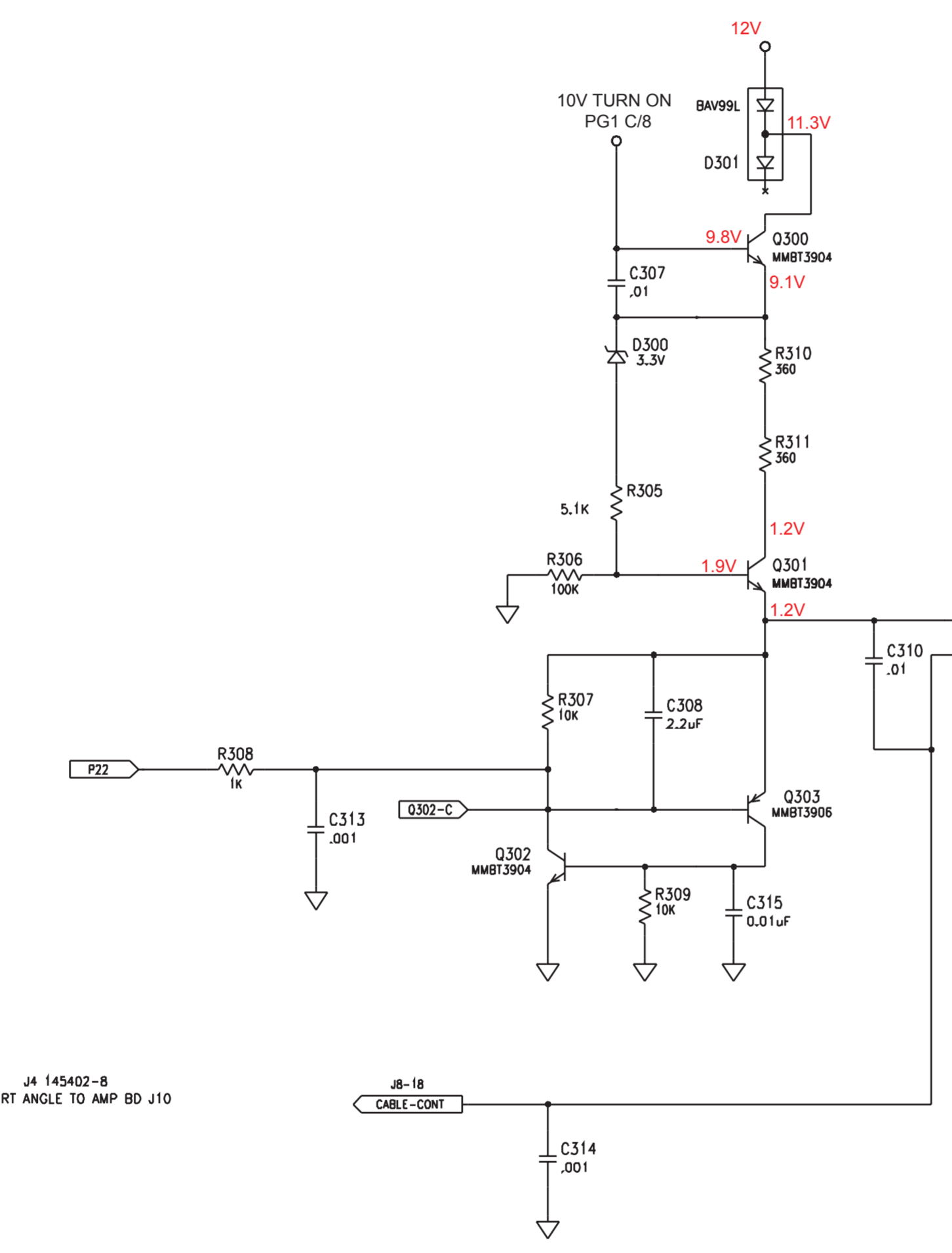
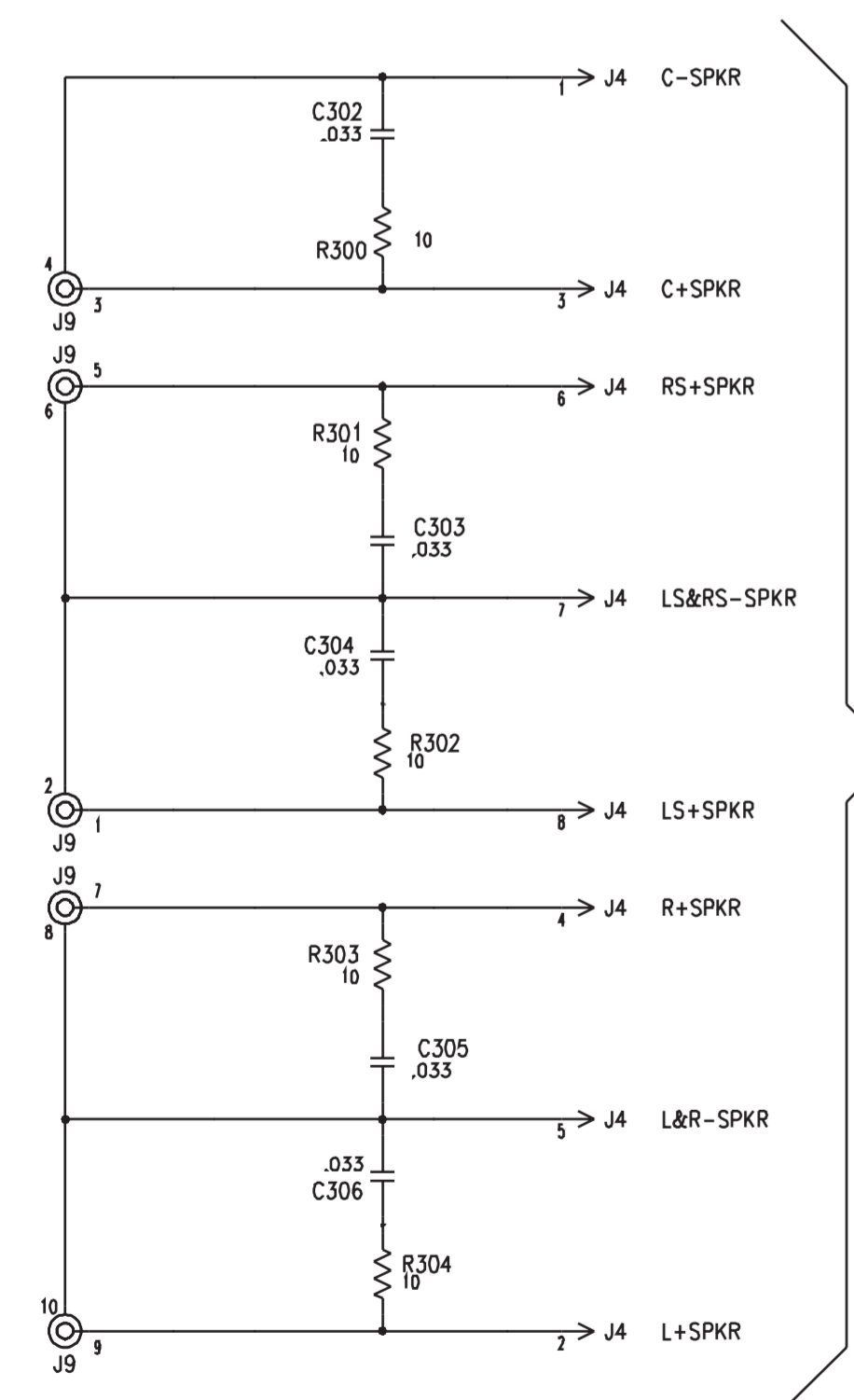
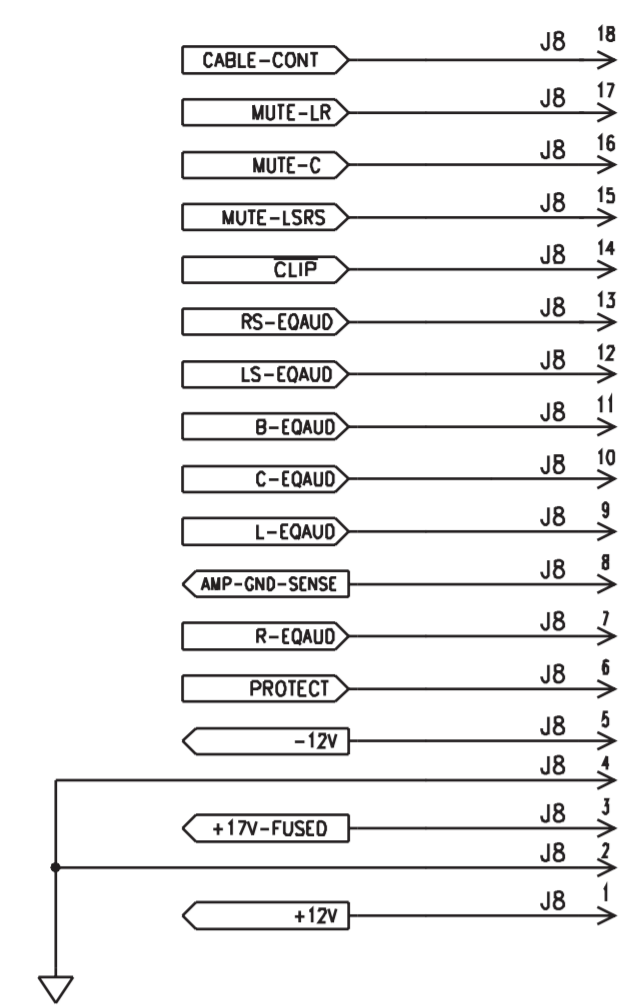

J4 145402-B  
RT ANGLE TO AMP BD J10

NOTES:  
Power supply voltages drop to zero when console is turned off.

8 7 6 5 4 3 2 1

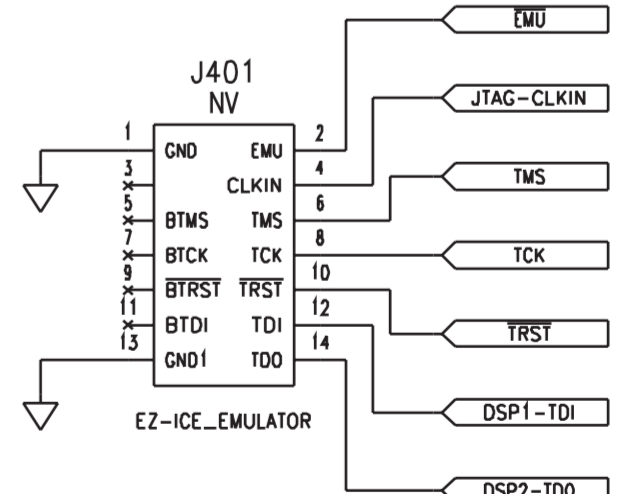
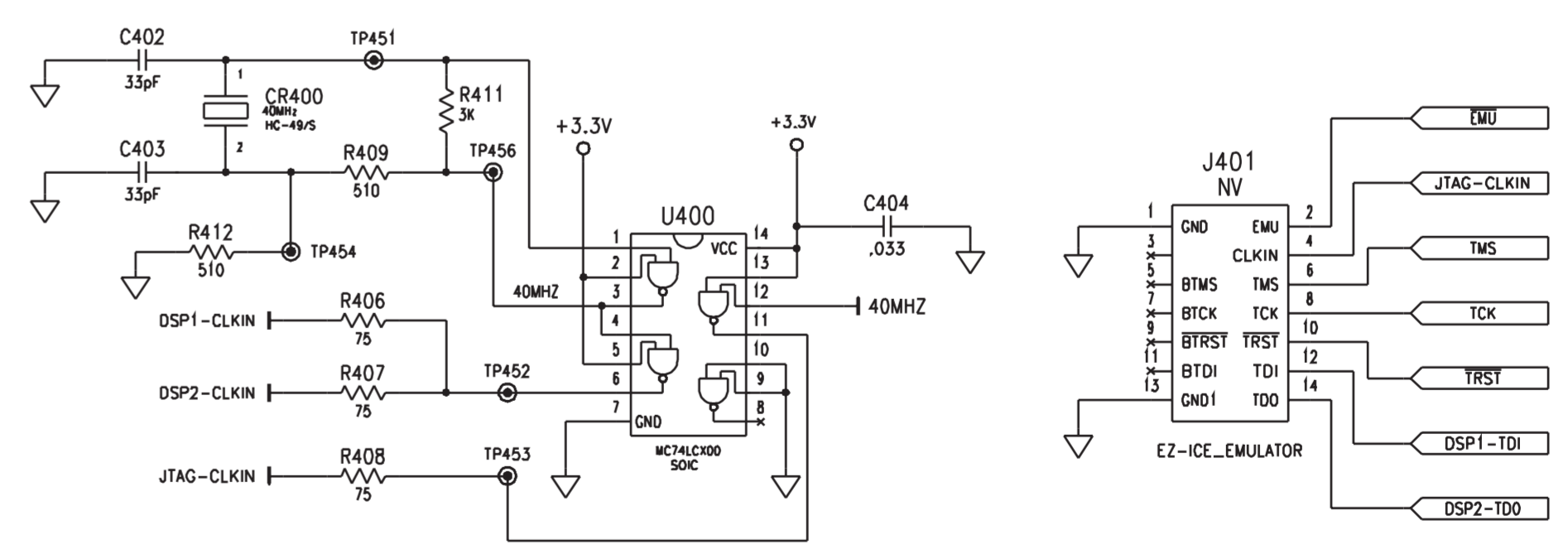
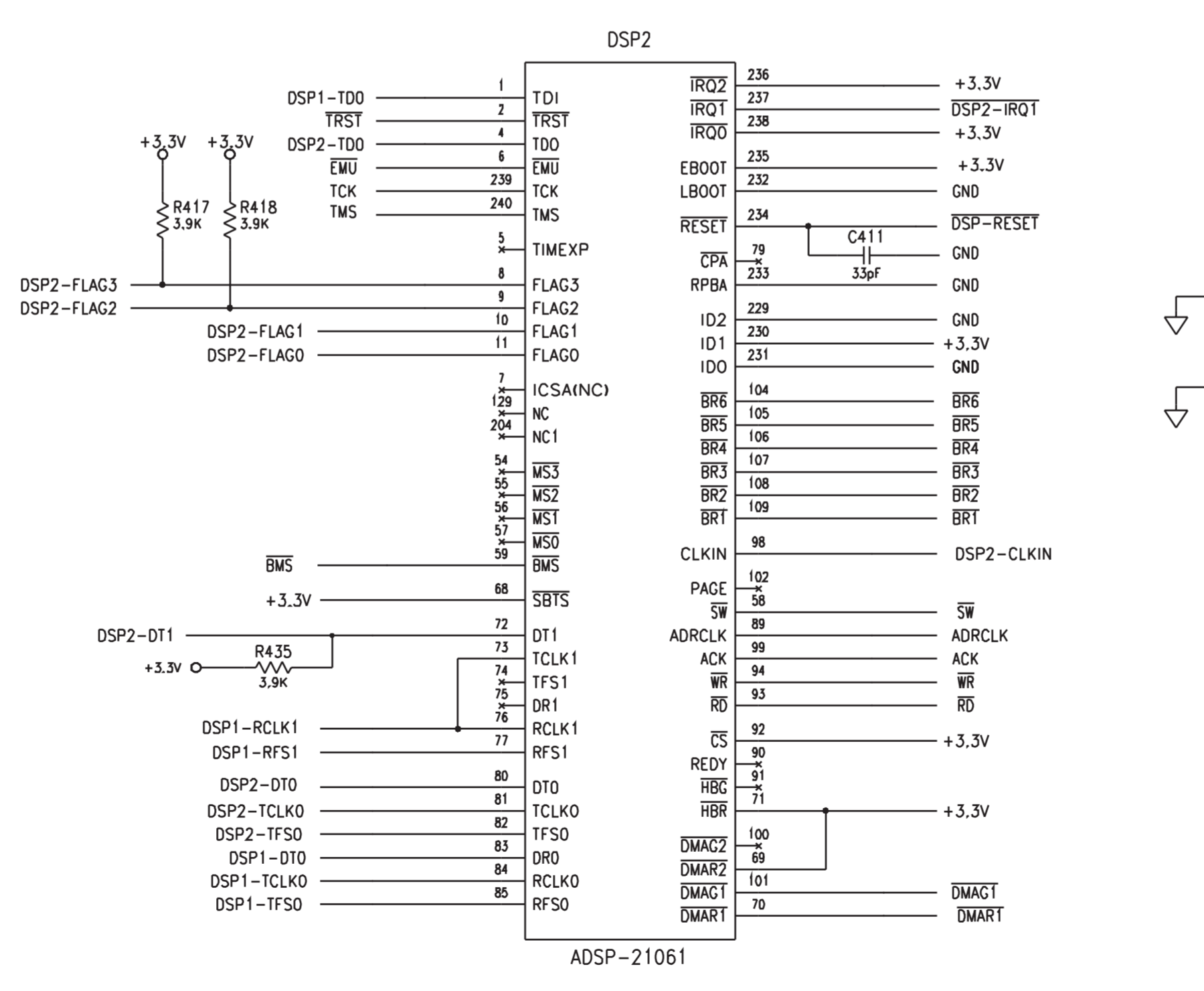
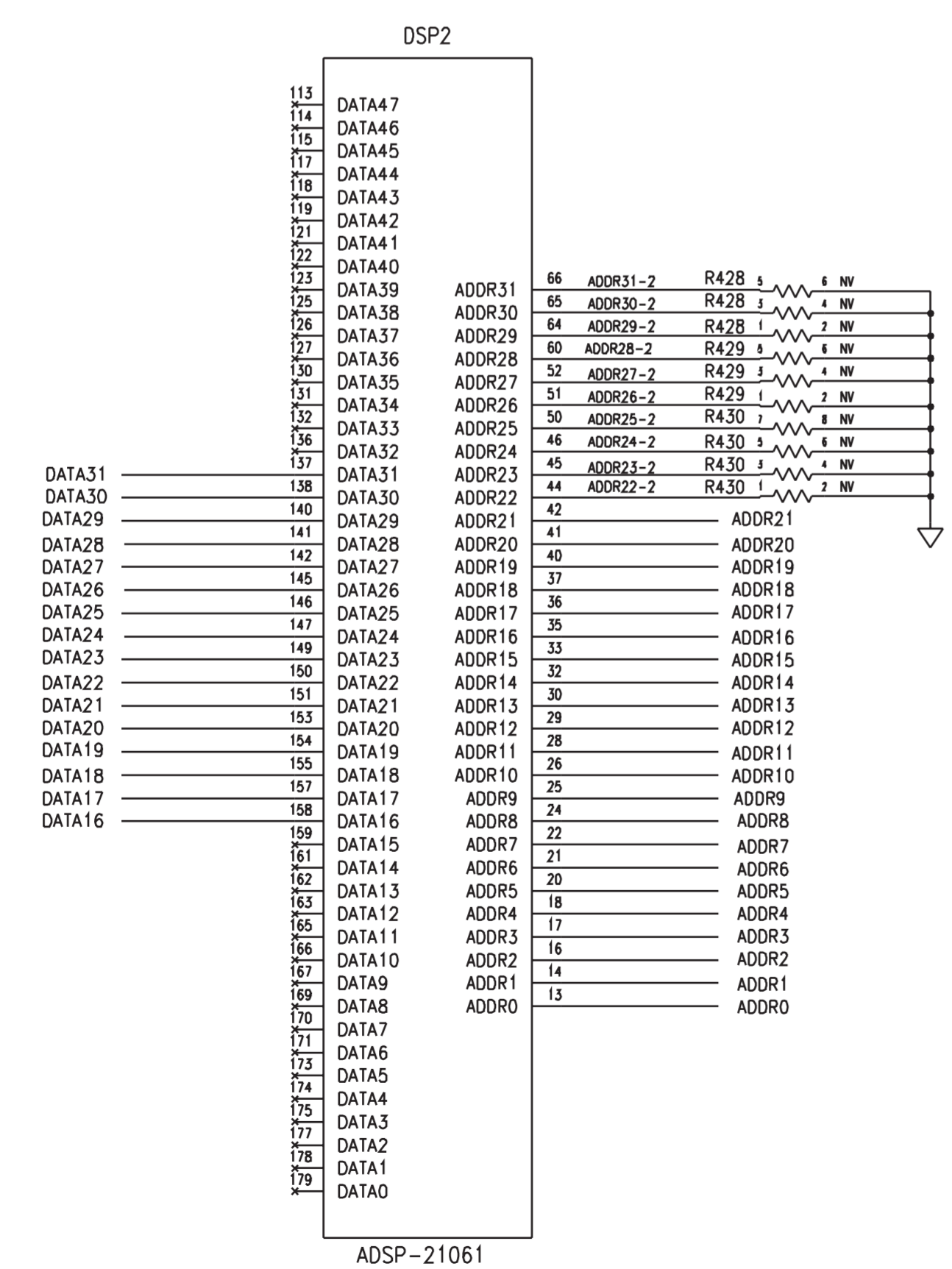
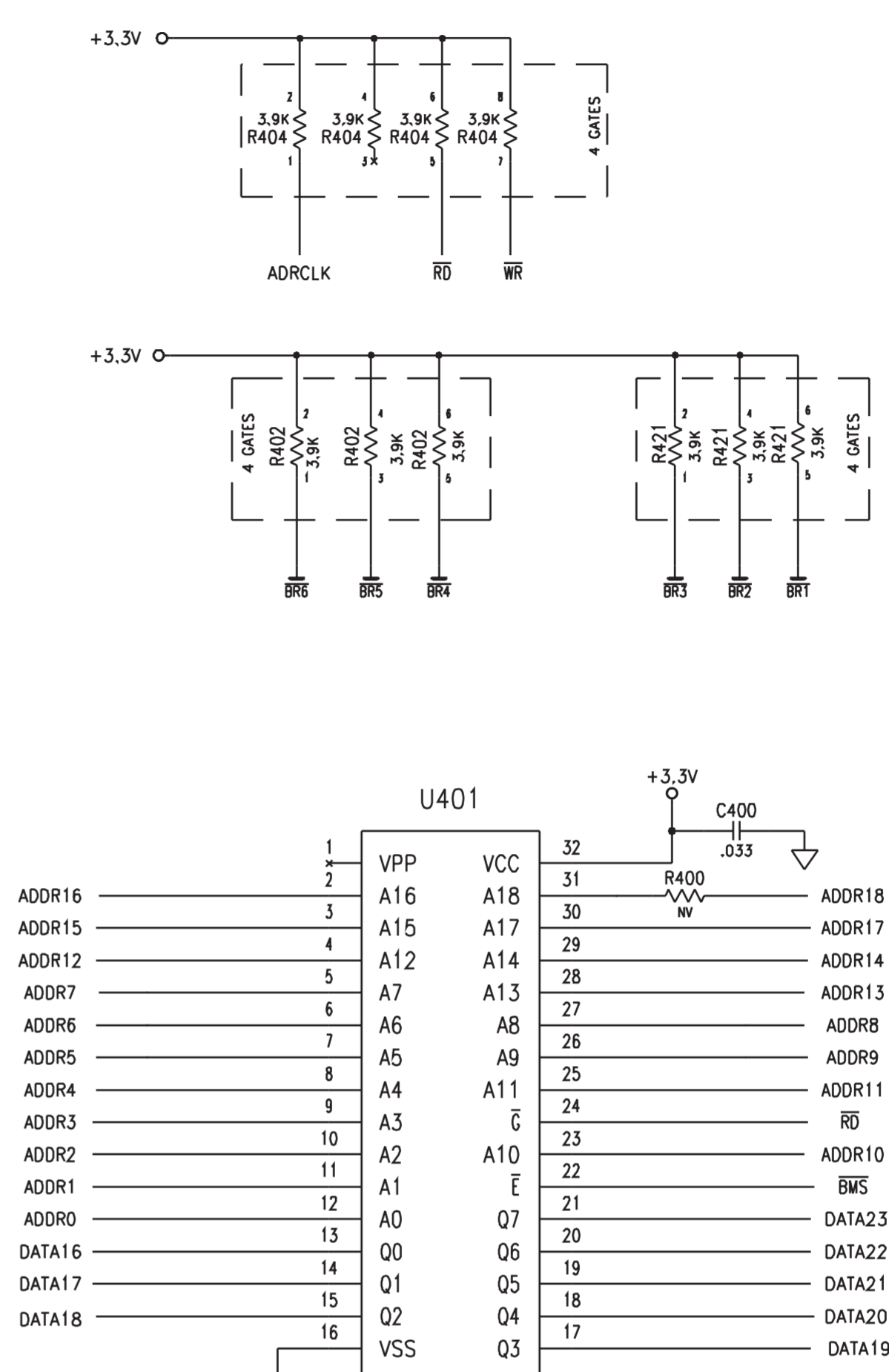
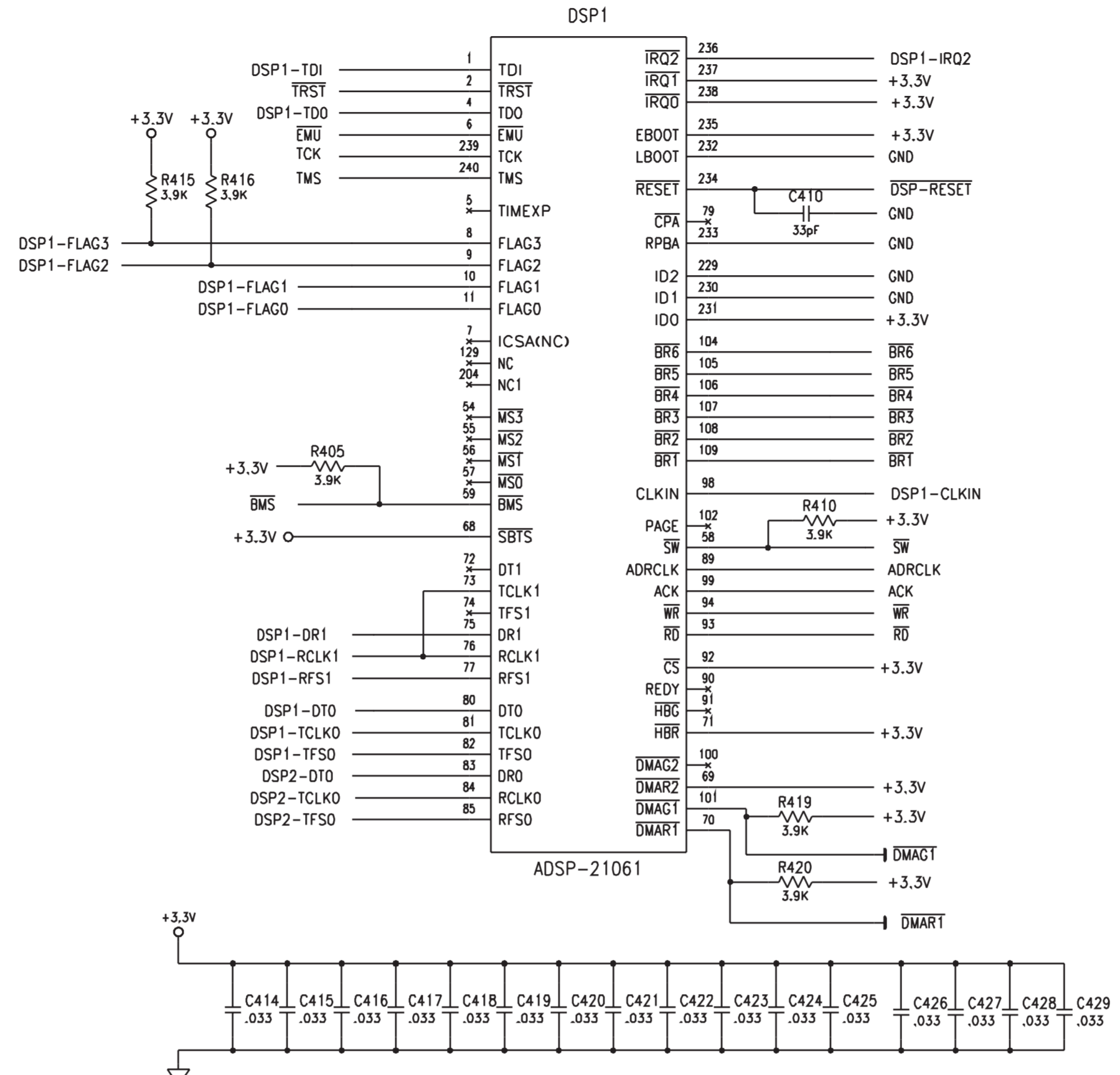
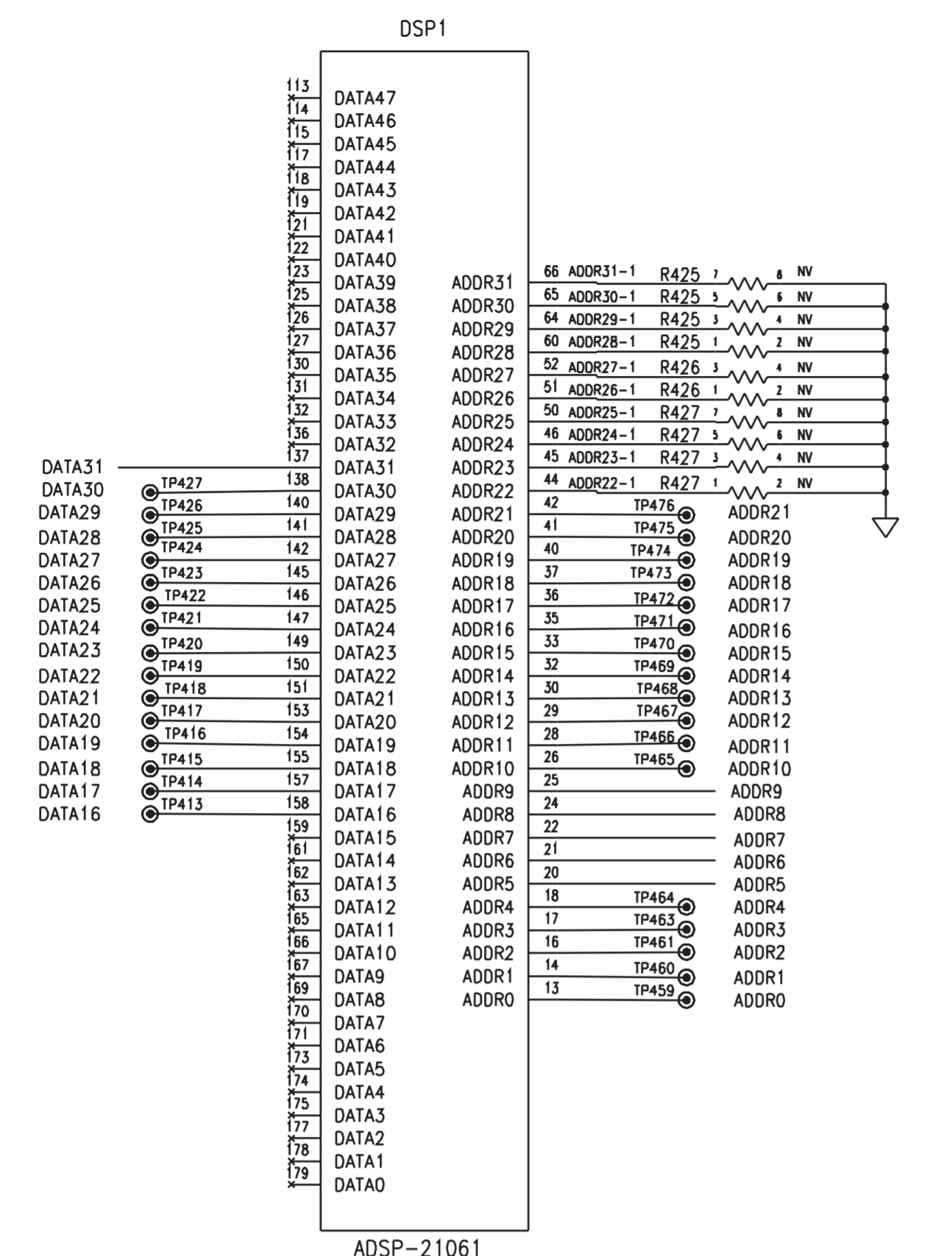

NOTES:  
Power supply voltages drop to zero when console is turned off.

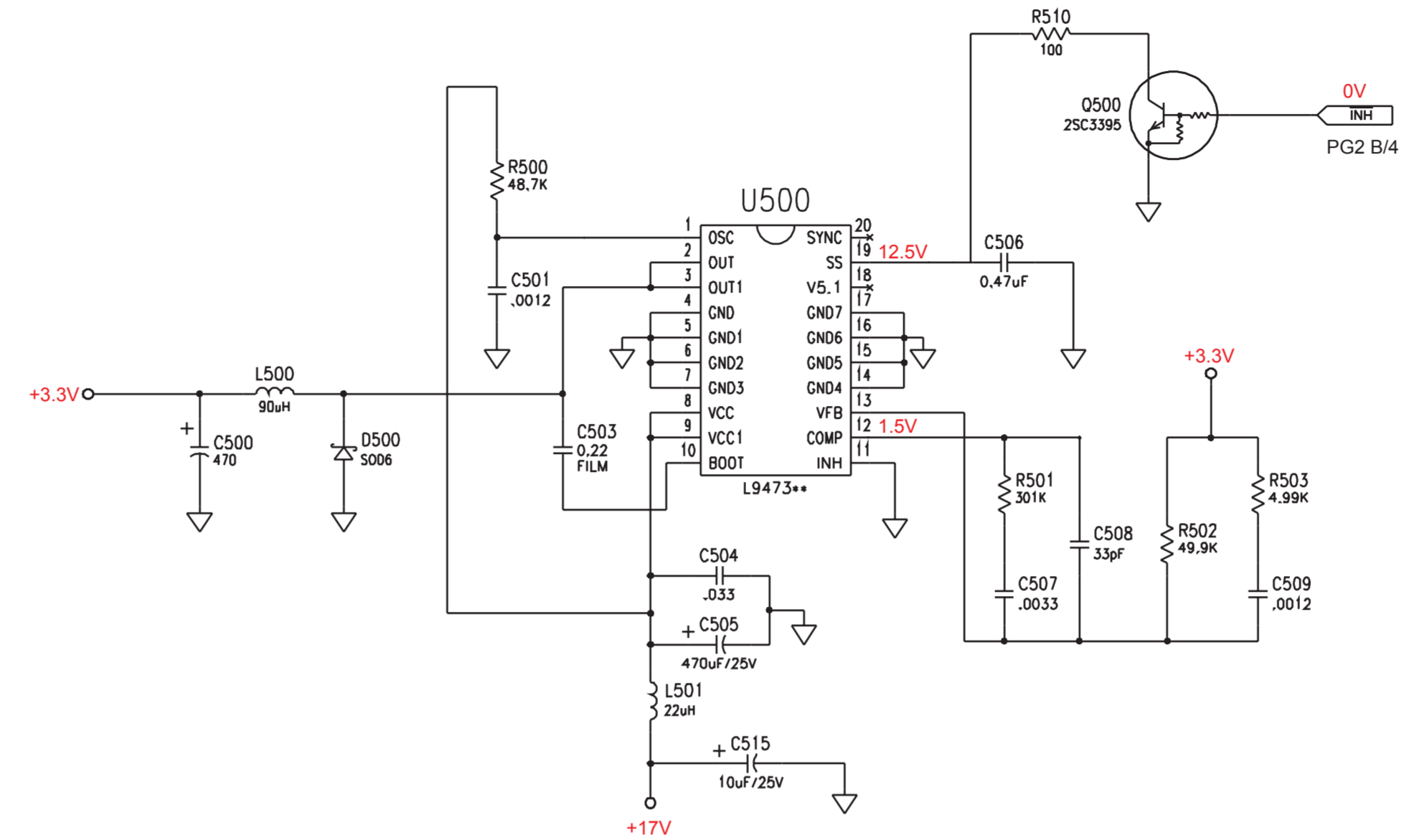
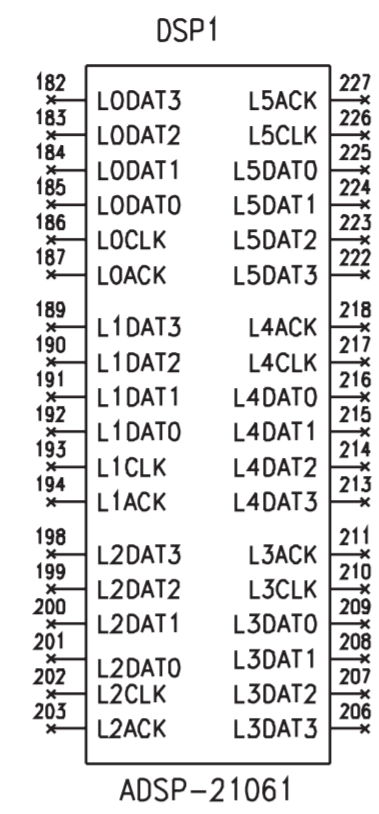
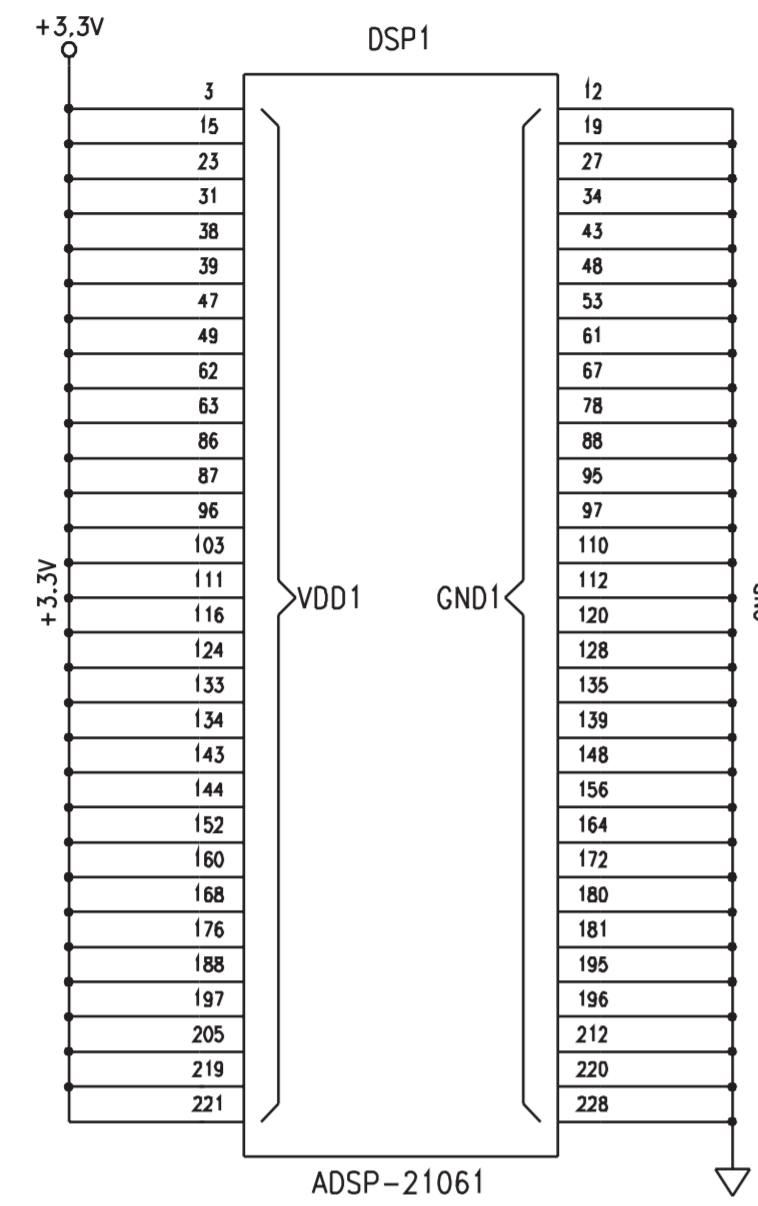

NOTE - At power down, 5V will be present at the base of Q500 for approximately 5 seconds to allow pin 19 of U500 to be pulled low, shutting off the regulator. The 3.3V supply is turned off as part of the normal power down sequence.

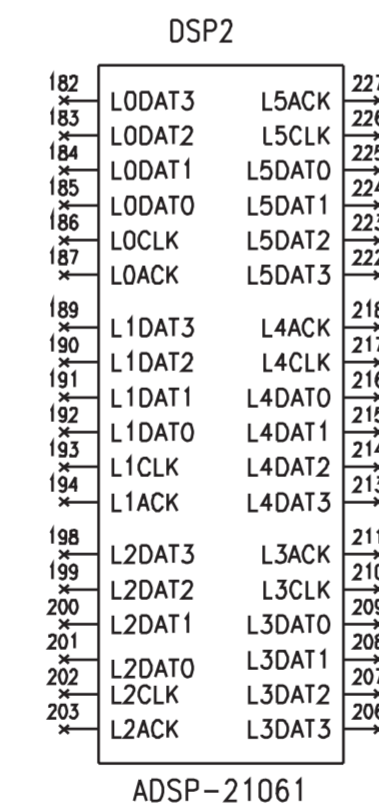
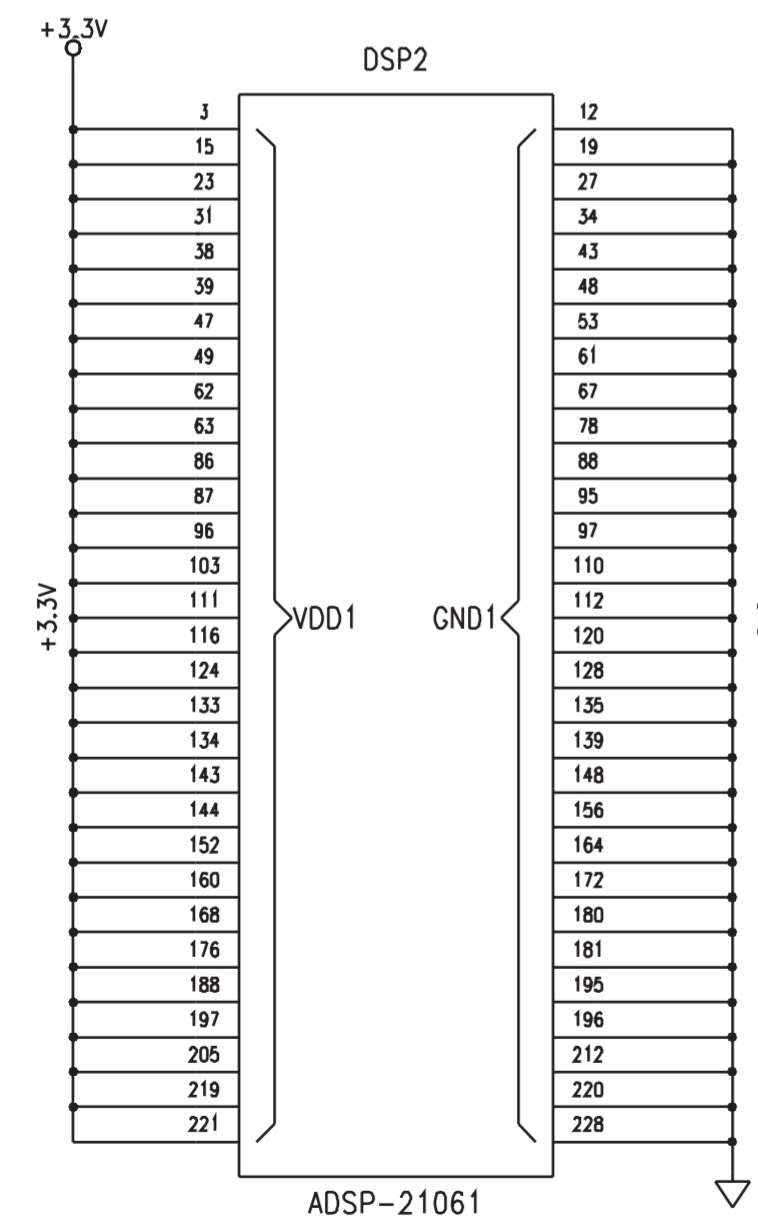
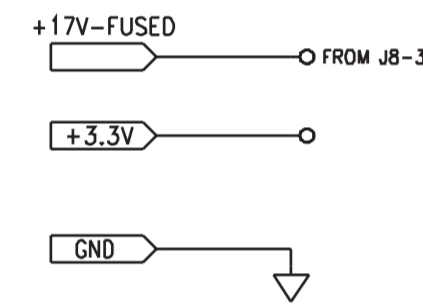

NOTES:  
Power supply voltages drop to zero when console is turned off.